

CONFLUO STANDARD BLACK GLASS, WHITE GLASS, CERAMIC DRY 1



CONFLUO STANDARD BLACK GLASS, WHITE GLASS, CERAMIC DRY 1

CONFLUO STANDARD drain “STANDARD CERAMIC BLACK/WHITE GLASS DRY 1” made of PP with no side inlets, with one horizontal DN 50mm outlet adjustable under the angle of maximum 15°, minimum installation height of 78mm and flow rate of 48l/min.

Base of drain with a socket (siphon) of a dry drain, which can be removed, water sealing height of 38mm, with hoop for hydroisolation which can also be removed if necessary and in which it is possible to attach flange for hydroisolation and height-adjustable carrier of a grid.

Stainless steel mask and black/white glass, or ceramic holder dimensions of 94x94mm.

IMPORTANT TECHNICAL INFORMATION	
Minimum installation height	78mm
Flow rate	48 l/min
Outlet	Ø50
Water seal height	38 mm
Grid load class (by EN 1253)	K3 with stand 300 kg of pressure
Body material	PP

DRAIN ADVANTAGE:

- Adjustable angle by 15°
- Base rotation 360°
- Easy installation and maintenance
- High flow rate

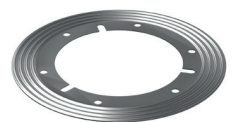
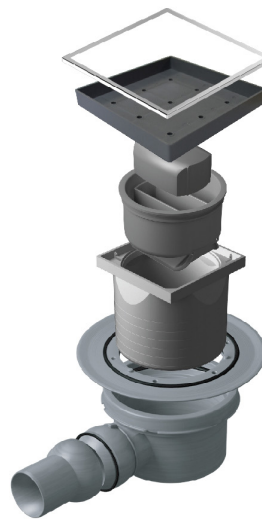
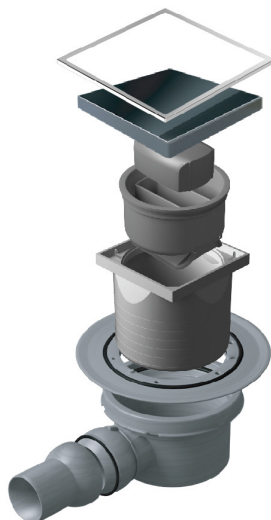
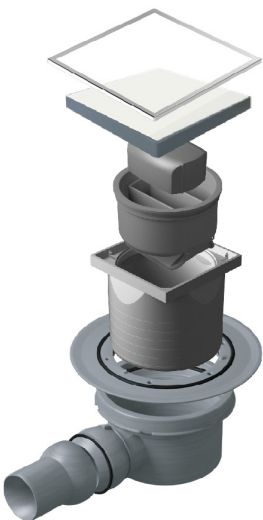
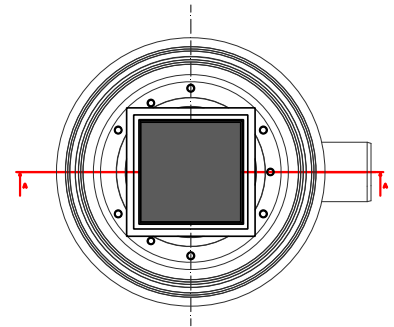
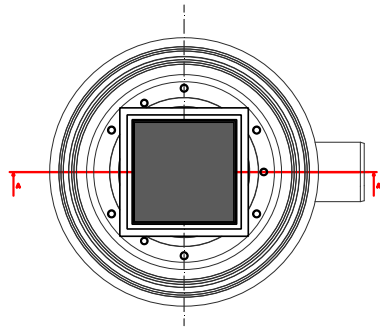
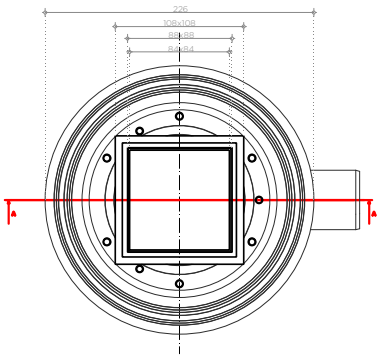
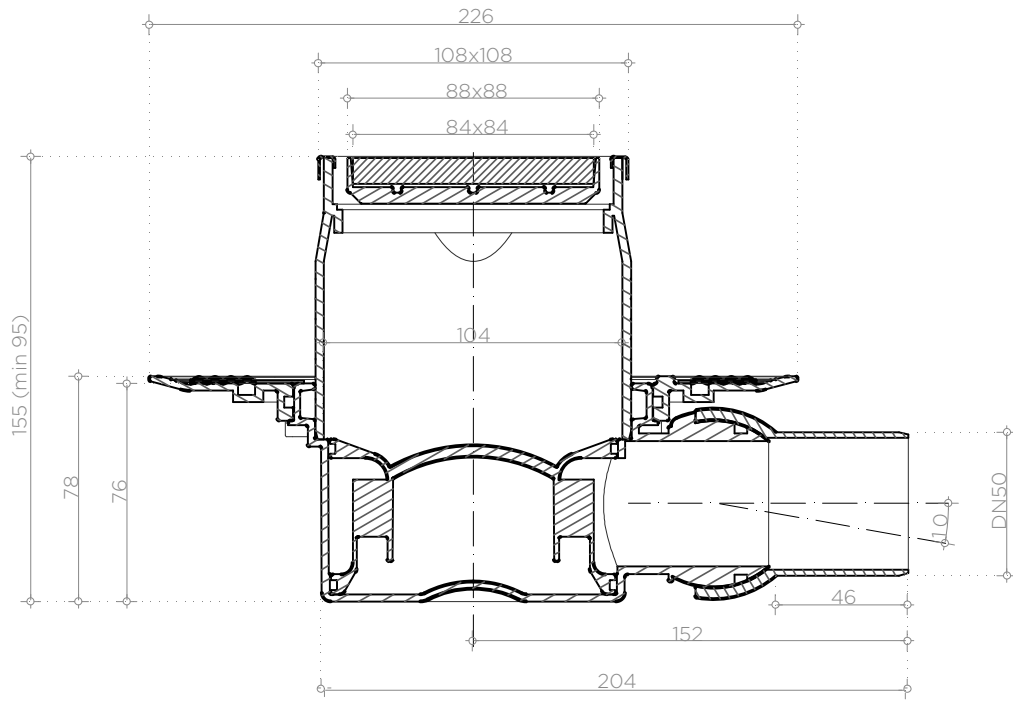
Hydroisolation flange optional

CODE	NAME	WEIGHT	BOX DIMENSIONS
13000101	CONFLUO "DRY 1 BLACK GLASS" 10X10	0,924kg	300mmx200mmx250mm
13000104	CONFLUO "DRY 1 WHITE GLASS" 10X10	0,924kg	300mmx200mmx250mm
13000107	CONFLUO "DRY 1 CERAMIC" 10X10	0,759kg	300mmx200mmx250mm
13000319	CONF "DRY 1 BLACK GLASS" 10X10 WITH FLNG	1,28kg	300mmx200mmx250mm
13000324	CONF "DRY 1 WHITE GLASS" 10X10 WITH FLNG	1,28kg	300mmx200mmx250mm
13000329	CONF "DRY 1 CERAMIC" 10X10 WITH FLANGE	0,863kg	300mmx200mmx250mm

