



GARBAGE CANS

120L / 240L

GARBAGE CAN 120L

CHARACTERISTICS

- Garbage can volume: 120l
- Garbage can dimensions: (LxWxH) 560x480x940
- Maximum load capacity of the garbage can: 100 ± 5 kg
- Garbage can weight: 9,5 ± 3,2 kg
- Garbage can is made of high density polyethylene (HDPE)
- Wheel axle is made of stainless steel
- number of wheels: 2 wheels
- Thermal stability **-18°C to +23°C**
- Diameter 200mm, with plastic rims
- Load bearing capacity per wheel: 160 kg, proved by testing report
- Weight of loaded garbage 60 kg

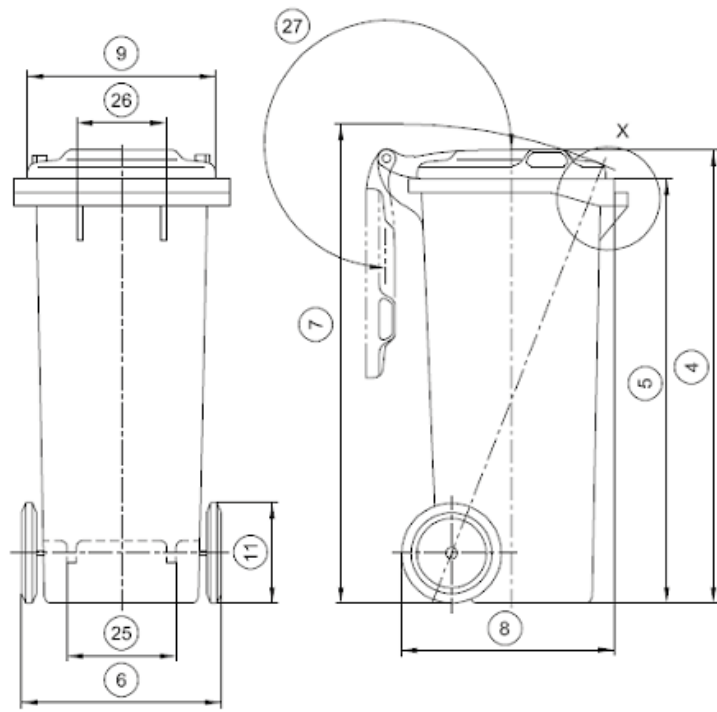

- Garbage can is constructed with reinforcement for lifter of garbage disposal truck, by which the garbage can is automatically discharged.

- Garbage can has a handle that enables easy handling.



- Possibility of placing openings for the separation: PET, paper, cans and glass.



- The possibility of making labels on request.



- Garbage can is made with smooth outer and inner surface.
- Garbage can is produced in chrome green colour, with option of manufacturing them in other colours on buyers request.
- Markings with serial number can be arranged on buyers request.
- Garbage can is made of recyclable material.
- Garbage can is manufactured according to demands of the standard EN 840, and fully meets the required characteristics.
- Garbage can is resistant to acids and organic alkaline thinners.

015000

TESTS:

Cans satisfy the requirements of European norms by which have been made and tested.

TEST of impact EN 840-5 at point 4.7.2.	TEST of falling EN 840-5 at point 4.7.5.
TEST of stability EN 840-5 at point 4.8.	TESTING of aging EN 840-5 at point 4:11:10

GARBAGE CAN 140L

CHARACTERISTICS

- Garbage can volume: 140l
- Garbage can dimensions: (LxWxH) 550x480x1060
- Maximum load capacity of the garbage can: 115 kg
- Garbage can weight: 10 ± 2 kg
- Garbage can is made of high density polyethylene (HDPE)
- Wheel axle is made of stainless steel
- number of wheels: 2 wheels
- Thermal stability **-18°C to +23°C**
- Diameter 200mm, with plastic rims
- Load bearing capacity per wheel: 150-160kg, proved by testing report
- Weight of loaded garbage 70 kg

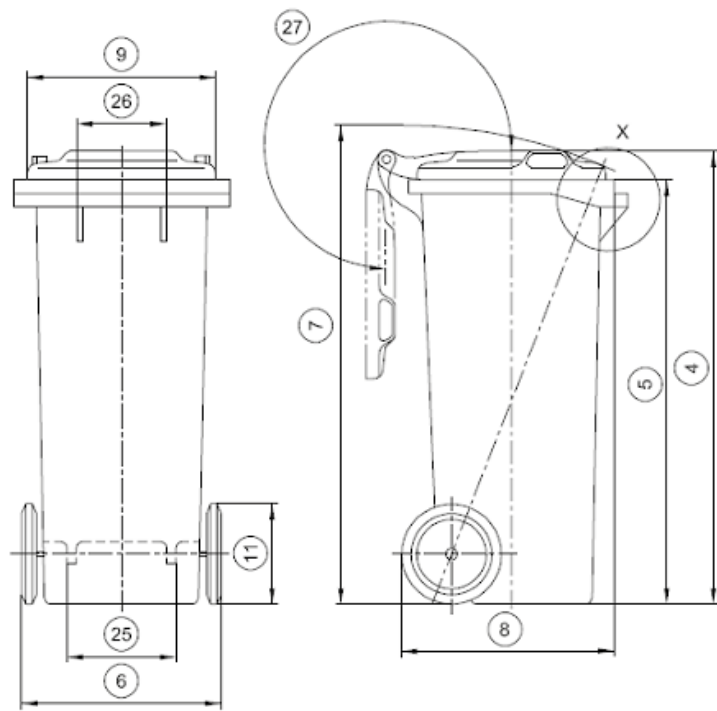

- Garbage can is constructed with reinforcement for lifter of garbage disposal truck, by which the garbage can is automatically discharged.

- Garbage can has a handle that enables easy handling.



- Possibility of placing openings for the separation: PET, paper, cans and glass.



- The possibility of making labels on request.



- Garbage can is made with smooth outer and inner surface.
- Garbage can is produced in chrome green colour, with option of manufacturing them in other colours on buyers request.
- Markings with serial number can be arranged on buyers request.
- Garbage can is made of recyclable material.
- Garbage can is manufactured according to demands of the standard EN 840, and fully meets the required characteristics.
- Garbage can is resistant to acids and organic alkaline thinners.

015000

TESTS:

Cans satisfy the requirements of European norms by which have been made and tested.

TEST of impact EN 840-5 at point 4.7.2.

TEST of falling EN 840-5 at point 4.7.5.

TEST of stability EN 840-5 at point 4.8.

TESTING of aging EN 840-5 at point 4:11:10

GARBAGE CAN 240L

CHARACTERISTICS

- Garbage can volume: 240l
- Garbage can dimensions: (LxWxH) 710x580x1060mm
- Gross permitted mass 110kg
- Weight of can: 11.45kg
- Can is made of high density polyethylene (HDPE)
- Axle for wheels, stainless steel / 2 pcs
- Temperature resistance **-18°C** up to **+23°C**
- The wheels are solid rubber Ø 200 mm diameter with plastic rim
- Increased body cans
- UV stability

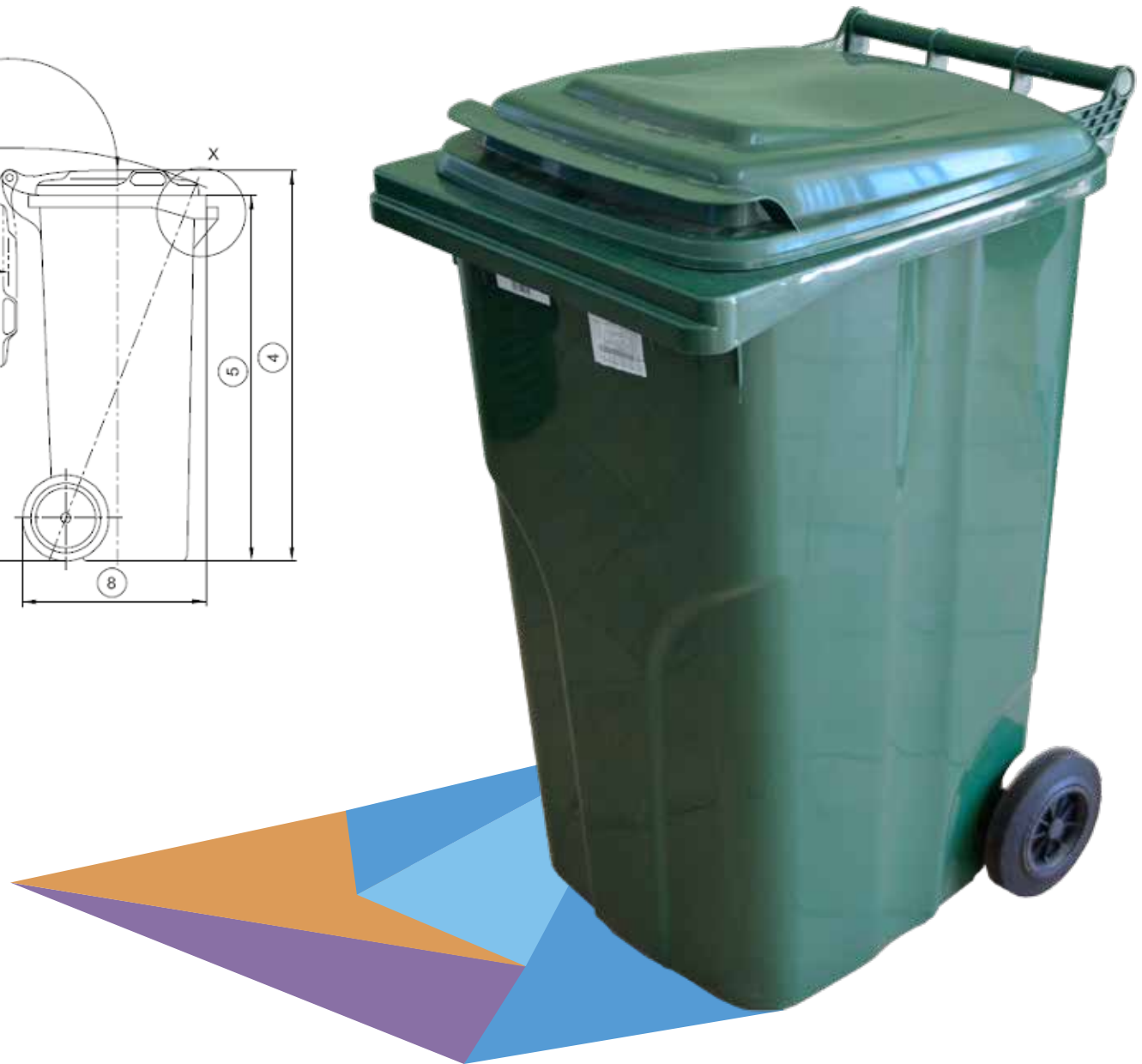
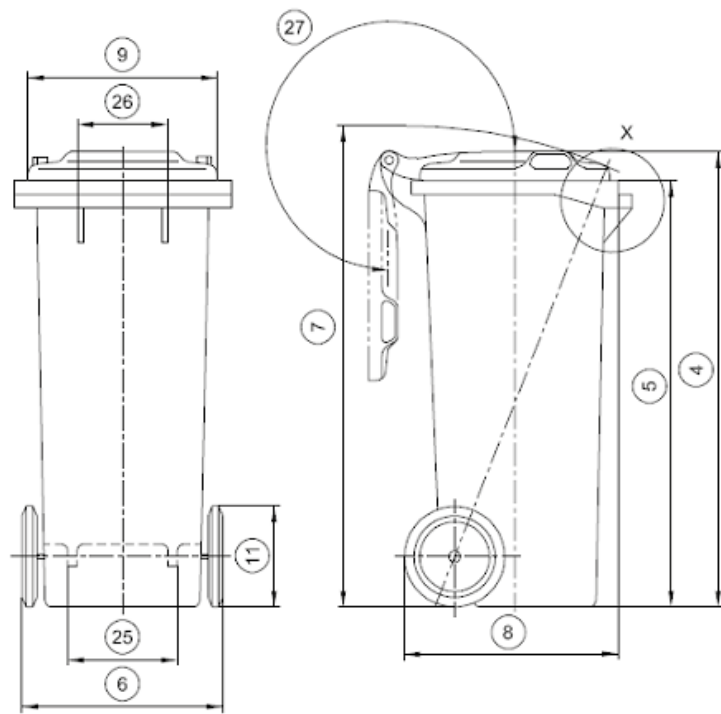

- Bin is constructed so that there is reinforcement for the comb grabbing of garbage trucks with which the bucket is emptied



- Bin has a grip which enables easy handling



- Bins with smooth external and internal surfaces
 - Bin is green and there is a possibility of making them in different colors according to customer
 - At the customer's request bins may be marked by serial number.
- 015000
- The material cans are made of can be recycled
 - Can is made according to standard EN 840-2: 2013 Section 1, 5 and 6 and in full comply with prescribed characteristics
 - The possibility of making labels on request.

- The colors in which the bin is produced (all colors are available on customer request)



- The possibility of setting hole separation: PET, paper, cans and glass.



CAN LABELING ACCORDING TO EN 840-1:2013



Producer label on the left side of the body



European norm, nominal volume and mass are on the right side of the body



ILID INFORMATION

- Do not dispose flammable objects
- Noise level
- CE sign
- Recycling sign



Year and month of production, material label is on the bottom side of the body



Year and month of production are on the right side of the bin's body



Frontal label for grabbing and lifting the bin (A)
Bin name (Container)

- LAST COUNT IN THE TABLE PRESENTS THE YEAR AND MONTH OF PRODUCTION CANS