



TECHNICAL CATALOGUE

HTPP

PIPES AND FITTINGS



August 2016.

Content

GENERAL NOTES	2
ABOUT COMPANY	5
1. STANDARDS THAT APPLY ON PEŠTAN HTPP PIPES AND FITTINGS	6
2. BASIC INFORMATION ABOUT PEŠTAN PP PIPES AND FITTINGS	7
3. PACKAGING, TRANSPORTATION AND STORAGE	10
4. INSTALATION AND CONNECTION	14
5. THE USE OF PIPELINES	23
6. RESOLVING OF INTERFERENCE	30
7. MAINTENANCE	31
8. DISASSEMBLY AND REMOVAL	31
9. PROCESS IN POST USING	32
10. THE LIST OF ABBREVIATION	33
11. CATALOG OF PRODUCTS	35
12. CERTIFICATES	45
13. THE TABLE OF CHEMICAL RESISTANCE	47

GENERAL NOTES

Technical catalog is subject to change in certain intervals as a result of the production of new products and modification of the same. Because of that reason it is necessary to check if you have the latest version of technical catalog. Date of publication of the technical catalog is placed on the cover of the catalog and the latest version you can download from site www.pestan.net or request via mail office@pestan.net.

Fast access sections is provided with the help of pictogram

**Bitne
informacije**



**Bezbednosna
preporuka**



**Pravna
napomena**



Before starting the installation of Peštan HTPP pipes and fittings for sewerage, be sure to read all the recommendations related to safety and protection at work for your safety and the safety of people around you. All the time while you are installing system, use this technical instructions. In case that some of the details in this technical catalogue are not clear, please contact us on our mail : office@pestan.net

General safety recommendations:

- Consider all the common safety rules to prevent accidents during installation of pipes and fittings
- Provide sufficient light during installation of pipes and fittings
- Keep the work area clean
- Keep away children, pets and unauthorized persons from tools and place of installation of pipes and fittings (this is especially essential in the case of renovation)

Precautions when setting up the system

- If you have jewelry or other objects hanging, be sure to remove them before installing
- Cutting tools should be used and delayed in a manner to prevent injuries because they have sharp edges
- When cutting the pipe you should hold hand which is holding pipe on safe distance from cutting tools, and never do not put your hands near the area where the tool cuts pipe.
- When doing repair, maintenance or when changing place assembly, always disconnect the power supply on the tool.

Fire protection

Be sure to carefully review the cautions for fire protection as well as building regulations that apply in each special case with special emphasis on:

- Breakthrough through the ceiling, roof and walls
- Rooms with stricter requirements with prevention requirements for fire protection (review national regulations)

Personal Requirements

- Only authorized and trained persons can install Peštan's system
- Work on electrical systems or components of pipes may be executed only by persons who are trained and authorized for this purpose.





ABOUT US

Private company Peštan is a leader in the Balkan in manufacturing plastic pipes and fittings for water, sewerage and gas. The company was founded in 1989 and has dealt with production of water pipes made of polyethylene. With time company has introduced new materials (polypropylene and PVC) and spread production program. Today, the offer can count over 5000 products, that includes pipes and fittings and PVC profiles, luxurious and modern drains, tape for irrigation etc. The main distribution center is located in Bukovik, near town Arandjelovac, and foreign representation are located in countries in the region: Bosnia and Herzegovina, Montenegro, Romania, Croatia, Macedonia, Bulgaria. The company is present in the market of Europe, Russia, the Middle East, North Africa, Latin America and the United States. Company is export-oriented and sales implements in over 60 countries!

The entire production is adapted to the European standards which has proven with international certificates for product quality: DVGW, MPA, SABS, IMS, IGH, ZIK, VUPS, EMI.

Working as much as possible to satisfy customer needs, the company continuously innovates and improves human resources and equipment. The introduction of WCM and WMS systems has increased efficiency, contributed to the deployment of cost and to the professional maintenance. The owner of the company, Miodrag Petković, and over 1000 employees, with joint efforts justify slogan of company: Quality. Reliability. Innovation.



1 STANDARDS

Standards that apply on

Peštan HTPP pipes and fittings

SRPS EN 1451-1:2008 Piping systems of plastic for soil and waste discharge (low and high temperature) within the building structure - Polypropylene (PP) - Part 1: Specifications for pipes, fittings and the system

EN 1451-1:1998 Plastics piping systems for soil and waste discharge (low and high temperature) within the building structure - Polypropylene (PP) - Part 1: Specifications for pipes, fittings and the system

SRPS EN ISO 3126:2009 Piping systems of plastics - plastics components - Determination of dimensions

EN ISO 3126:2005 Plastics piping systems - Plastics components - Determination of dimensions

SRPS EN 744:2008 Piping systems and ducting plastics - Thermoplastics pipes - Test method for resistance to external shocks clock method

EN 744:1995 Plastics piping and ducting systems - Thermoplastics pipes - Test method for resistance to external blows by the round-the-clock method

SRPS EN ISO 2505:2013 Thermoplastics pipes - Dimensional stability during heat - Test method and parameters

EN ISO 2505:2005 Thermoplastics pipes - Longitudinal reversion - Test method and parameters

SRPS EN ISO 1133-1:2013 Plastics - Determination of the melt mass flow rate (MFR) and melt volume flow rate (MVR) thermoplastic materials - Part 1: Standard method

ISO 1133-1:2011 Plastics - Determination of the melt mass-flow rate (MFR) and melt volume-flow rate (MVR) of thermoplastics - Part 1: Standard method

SRPS EN ISO 580:2009 Piping systems and ducting plastics - Injection pressed thermo plastic fittings - Methods for visually assessing the effects of heating

ISO 580:2005 Plastics piping and ducting systems - Injection-moulded thermoplastics fittings - Methods for visually assessing the effects of heating

SRPS EN 1053:2008 Piping systems of plastic - Thermoplastic push piping systems - Test method for watertightness

EN 1053:1995 Plastics piping systems - Thermoplastics piping systems for non-pressure applications - Test method for watertightness

SRPS EN 681-1:2007 Elastomeric seals - Materials requirements for pipe joint seals used in water and drainage applications - Part 1: Rubber

EN 681-1:1996/A3:2005 Elastomeric seals - Material requirements for pipe joint seals used in water and drainage applications - Part 1: Vulcanized rubber

SRPS EN 12056-1:2011 Gravity drainage systems for waste water in buildings - Part 1: General requirements and performance requirements

EN 12056-1:2000 Gravity drainage systems inside buildings - Part 1: General and performance requirements

SRPS EN 12056-2:2011 Gravity drainage systems for waste water in buildings - Part 2: Sanitary pipe network, plan and budget

EN 12056-2:2000 Gravity drainage systems inside buildings - Part 2: Sanitary pipework, layout and calculation

SRPS EN 12056-3:2011 Gravity drainage systems for waste water in buildings - Part 3: Roof drainage, layout and calculation

EN 12056-3:2000 Gravity drainage systems inside buildings - Part 3: Roof drainage, layout and calculation

SRPS EN 12056-4:2011 Gravity drainage systems for waste water in buildings - Part 4: Pumping station for waste water - Plan and Budget

EN 12056-4:2000 Gravity drainage systems inside buildings - Part 4: Wastewater lifting plants - Layout and calculation

SRPS EN 12056-5:2011 Gravity drainage systems for waste water in buildings - Part 5: Installation and testing, instructions for operation, maintenance and use

EN 12056-4:2000 Gravity drainage systems inside buildings - Part 5: Installation and testing, instructions for operation, maintenance and use

2 INFORMATION

BASIC INFORMATION ABOUT PEŠTAN PP PIPES AND FITTINGS

Basic information about Peštan PP pipes and fittings. The program HT (PP) pipes and fittings from the company Peštan is produced from PP-H (polypropylene homopolymers) by latest technology extrusion three-layer tubes per the requirements of European Standard 1451. Polypropylene has excellent mechanical and thermal properties, it doesn't contain heavy metals and it is suitable for recycling and subsequently use for other purposes. Recyclable without loss of mechanical properties make polypropylene an ecologically suitable material. Pipes and fittings from HTPP Peštan production programs are intended for soil and waste discharge (low and high temperature) within the building structure. HTPP system is universal and it can be used for drainage of contaminated water, for one-floor houses to large multiple storey buildings. Editing and manipulation of elements of the pipeline is very simple and it is described in the forthcoming chapters of this technical catalog. Connecting pipes are made via the connecting elements, the fitting, while the watertightness is provided with compound of rubber sealing rings. Inner layer of polypropylene sewage pipes has a very low roughness, resulting in good hydraulic characteristics, high resistance to abrasion, as well as to the retention of sediments and bacterial cultures for the inner wall of the pipe. For easier inspection of pipeline, inner layer of pipe is made in white color.

HTPP pipes and fitting are resistant to corrosion and their lifespan is over 50 years.

Pipes and fittings possess exceptional thermal stability and they are resistant to:

- short thermal loads of hot water of up to 95 ° C (30 seconds / day)
- continuously up to 60 ° C (5hrs / day = 87,600 hrs / 50 years)

In terms of chemical resistance HT (PP) pipes are resistant in: salt water, alcohol, acids, alkalis, sulphates, aggressive gas and all kinds of detergents. They are suitable for drainage of aggressive chemical waste, pH value of 2 (for very acid waste water) to 12 (for a very base wastewater).

HT (PP) program is sensitive to waste water containing a high percentage of gasoline (petrol), benzene or acetone. For a detailed chemical resistance pipeline

look table of chemical resistance, which is an integral part of this technical catalogs.

Connection of pipes and fittings are 100% resistant to leakage up to pressure of 0.5bar (5m water column)

The pipes are not intended for outdoor use due long-term volatility during UV radiation. Also pipes are not intended for installation in the ground. It is not advisable to perform installation of pipelines on temperatures below 5 ° C.

Polypropylene has excellent sound and thermal insulating properties (far better than eg. steel). In terms of fire protection, HT (PP) pipes program belong to flammability class B2 of DIN 4102, or belong to a group of normally flammable materials.

In Peštan HTPP production program pipe is included:

- HTPP pipe diameter and 160 with 32,40,50,75,90,110,125 with one socket
- HTPP pipe diameter and 160 with 32,40,50,75,90,110,125 with double socket

Peštan HTPP pipes consist three layers, where each layer contributes to the desired characteristics of the product. Illustration of the layers is shown in the picture below.

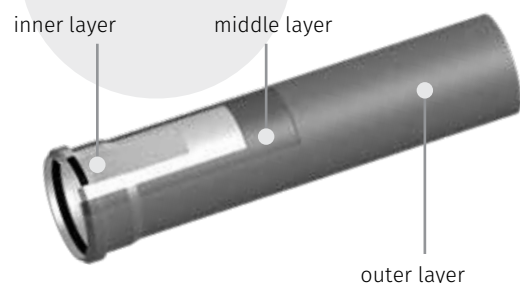

Inner layer: The smooth white inner surface prevents accumulation of sediment and reduces abrasion on the pipes. It allows easier inspection of the pipeline as it is white. It is resistant to increased temperature and chemicals.

Middle layer: Reinforced mineral fillers gives strength and flexibility to the pipes.

Outer layer: Provides pipes better impact resistance, and greater security during the handling and installation of the product.



Material	PP-H (polypropylene homopolymer)
Pipe structure	Three-layer composite pipe PPH-PPM-PPH
Density	pipes (Ø32-Ø50) - 0.9 g/cm ³ , pipes (Ø63-Ø160) - 0.8 g/cm ³ fitting - 0.9 g/cm ³
Hot water resistance	short term up to 95°C long term up to 60°C
Linear expansion coefficient	0.12 mm/m°C
Chemical resistance	pH 2- pH 12
E - modulus	1300-2000 MPa
Joining method	Push-fit sockets with inserted rubber ring - resistant to leakage up to pressure of 0.5bar
Application category	B (instalation in buildings)
Fire classification	B2 - normal inflamability
Sound insulation level	24 dB(A) sound insulation Level II

2.1 Marking pipes

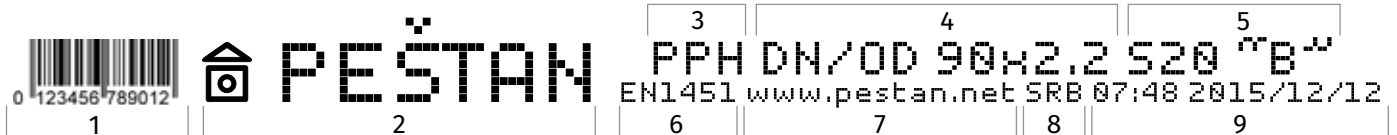

- | | |
|---|-------------------------------------|
| 1. Barcode | 6. Standard |
| 2. Logo | 7. Website |
| 3. Material | 8. Origin |
| 4. The external diameter and wall thickness | 9. The time and date of manufacture |
| 5. Class pipe S20 and the area of use B | |

EN 1451 s20								
	DN 32	DN 40	DN50	DN75	DN90	DN110	DN125	DN160
Dem (mm)	32	40	50	75	90	110	125	160
e(mm) min	1.8	1.8	1.8	1.9	2.2	2.7	3.1	3.9
d3(mm) min	38.6	49.6	59.6	84.5	99.5	120.5	137.5	174.3

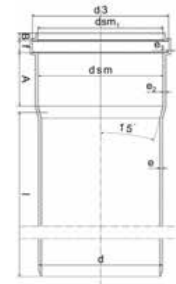

B(mm) min	5	5	5	5	5,0	6	7	9
A(mm) min	24	26	28	33	34,0	36	38	41
L(mm)	250, 500, 100, 1500, 2000, 2500, 3000, 3500 i 4000							

2.2 Marking fitting:

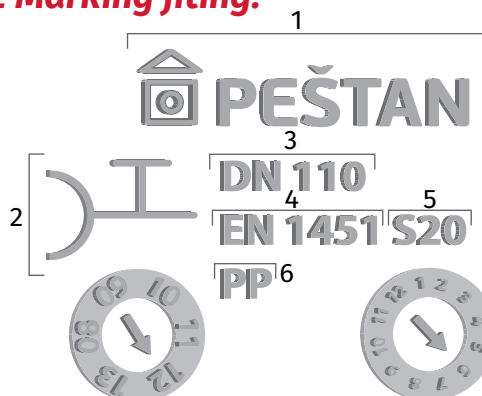

- | |
|---|
| 1. Logo |
| 2. Type of fitting HTB HT bend |
| 3. Nominal diameter and degree of angle |
| 4. Standard |
| 5. Class of fitting |
| 6. Identification of material |
| 7. Date |

On each fitting is a label with a bar code. For more details, please see a detailed list of products in HTPP production program. Therefore, the basic characteristics of HT (PP) pipes are:

- Made of very light material with excellent mechanical properties
- Simple and easy transport and handling,

- Fast and inexpensive mounting, merging the end of the pipe with socket
- They are resistant to corrosion in alkaline, acid or aggressive environment,
- They are fine electrical insulator,
- They are resistant to mechanical impact,

- The lifespan is longer than 50 years
- Practically no costs of pipeline maintenance,
- The sealing rings are made from EPDM rubber per standard EN 681..

2.3 Production program

Within Peštan HTPP production programe of fittings there are included:

- Bends of 15 °, 30 °, 45 °, 67.5 ° and 87.5 ° from diameter Ø32 to Ø160

- Single and double branches of 67.5 ° and 87.5 ° from diameter Ø32 to Ø160

- Double sockets, sleeve sockets, reducers, inspection pipes etc ...



HTB BEND 15°



HTB BEND 30°



HTB BEND 45°



HTB BEND 67.5°



HTB BEND 87.5°



HTAE BRANCH 45°



HTAE BRANCH 67.5°



HTAE BRANCH 87.5°



HTAE BRANCH 45°



HTDA DOUBLE BRANCH 67.5°



HTDA DOUBLE BRANCH 87.5°



HTRE INSPECTION PIPE



HTU DOUBLE SOCKET



HTR EXCENTRIC REDUCER



HTSW FLOOR WASTE GULLY



HTRE NON-RETURNABLE VALVE



3 PACKAGING

PACKAGING, TRANSPORTATION AND STORAGE

3.1 Packaging of pipes and fittings

Pestan HT (PP) pipes and fittings are packed in transport packages (unit and pallet) in the way convenient for customers. This way the package provides to customer safety during storage and easy handling.

Pipes in length 1m to 4m are packed in packages which, depending on the diameter and length, have certain number of pieces in unit packings and in whole packs. Every pack has certain number of unit packings that are packed on wooden beams and present final transport package ready for distribution to the customer.

Packaging of pipes

Standard packaging of HT (PP) pipes are on pallets and in packages. Pipes of all diameters in lengths of 0,25 and 0,50 meters are packed in cardboard boxes, which in a certain number, when packed up on a pallet represent the transport packaging. For creating the transport package basis used is EUR-pallet dimensions of 800 x 1200 mm.

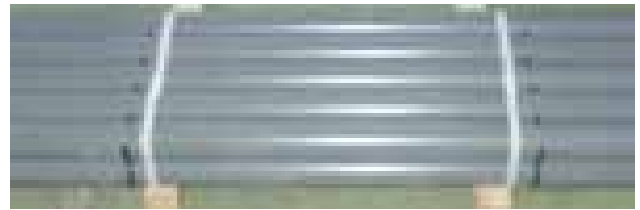

The unit package (a tie)



The packaging unit (box)



The transport package (pack, bundle)



The transport packaging unit (pallet)

Packaging of fittings

Standard packaging of connecting elements (fitting) are in the carton box of certain dimensions, which represent the unit of packaging, and in particular number make the transport packaging. Transport packages are formed on the EUR-pallets in dimensions 800 x 1200 mm and maximum height of 1400 mm.

Note: For accurate information regarding dimensions of packing etc. you can contact us on e mail: office@pestan.net.

3.2 Transportation and manipulation

Pestan HT(PP) pipes and all fittings are transported in appropriate transport vehicles. Loading area of transporting vehicles must be clean, with no waste flat and be sure no sharp protrusions (both on the floor of vehicles and on all sides of inner part of transport vehicles).

Dimensions of pallets, packages are of dimension to fill in the space of transport vehicle.

When it comes to loading transport packages (pipes and connecting elements) with a cardboard

packaging, packing are so defined that in the vehicles with height of 2.9 meters of cargo space can fit two packings- one on top of other.

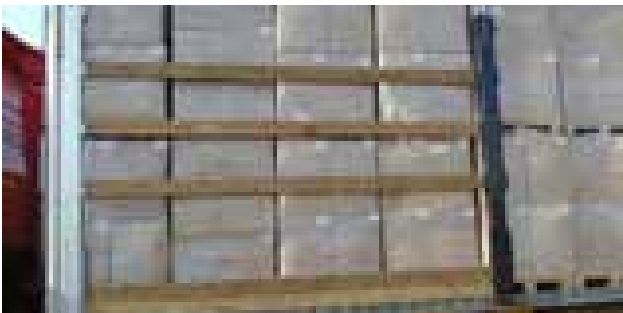

When loading transport packaging of pipes in packages, depending on the diameter of the pipe, the packages are packed in height in two or more levels. Pipe diameters $\phi 75$ to diameter $\phi 160$ are packed in two levels in height (height of the load compartment must be at least 2.9 meters).



Pipes diameters $\phi 32$ to $\phi 50$ are packed to transport vehicle into four levels according to overall height. (height of the loading area must be at least 2.9 meters).

When it comes to loading pipes outside the transport packaging (bulk), the pipe along its length must rely on a flat surface to avoid deformation of the same. The joints must therefore be alternately twist and pull for their entire length. This primarily has to be taken into account when pipes are of bigger length, in their case mishandling could lead to bending pipes at the end. When loading and unloading pipes, they should not be mishandled, pulled, pushed, especially on concrete and other rough surfaces. Any bending must be prevented, especially in the case of very low outside temperatures (temperatures below freezing).





3.3 Storage

Peštan HT(PP) pipes and fittings packed in cardboard packings are specifically stored in closed space (Shelf warehouses, one pallet – one pallet space).



Peštan HT(PP) pipes and fittings packed in cardboard packings are specifically stored in closed space (Shelf warehouses, one pallet – one pallet space).

If there is not a shelf warehouse, recommendation is that transport packings as these are stored in closed space and in one level (do not put pallet on top of another).

When there is no transportation packing but the goods arrived to customer in unit packs, they should be stored on pallets that are dry and clean. Boxes can be piled up one on another. Boxes mustn't be packed out of pallet or to be backed without a base that can hold them.

For storage of transport packaging of HT(PP) pipes and fittings, warehouses need to meet certain conditions.

Recommendation for storage:

- Transport packaging should be stored in dry, clean, indoors, where the temperature is between 10 and 30 ° C and a relative humidity between 50 and 60%.
- They should be protected from direct sunlight, moisture and heat and also need to be protected from the high temperature fluctuations as this may lead to occurrence of condensation and loss of functional properties of cardboard boxes.

Peštan HT (PP) pipes length from 1 to 4 meters can be stored in closed and in the open area. When pipes are stored in the open, that area should be protected from direct influence of sunlight by protective UV stable foil or canopy. It is recommended that these and transportation packaging are stored in an enclosed space, or space that is shaded.

No matter where are stored, whether indoors or outdoors, the packages should not be stacked in more than one level (from $\varnothing 75$ to diameter $\varnothing 160$), and not more than two levels of pipes diameters of $\varnothing 32$ to diameter $\varnothing 50$.



Although withstanding high temperatures it is not recommended long-term storage of pipes near a heat source. In addition to this it is strictly required to ensure that the pipe during storage does not

come into contact with materials damaging for polypropylene (eg. motor fuel, solutions, wood preservatives).

In the case of bulk pipes (or single pieces packages) attention should be paid to the following:

- pipes should be stored on a flat surface
- pipes should be placed on the wooden beams so the sockets of the pipe would not touch the surface and get deformed.
- pipes should not be dropped, dragged and pushed on uneven surfaces during stacking.
- pay attention to the way of stacking pipes (alternately rotate pipes so the sockets on the ends are free and therefore do not allow their deformation).
- ensure that packed pipes are secured from the sides.
- height of stacked pipes must not exceed a height of 1.5 meter
- pipes are to be stored indoors if there are conditions, if not pipes are stored in a shaded area or cover with UV stable protective film.

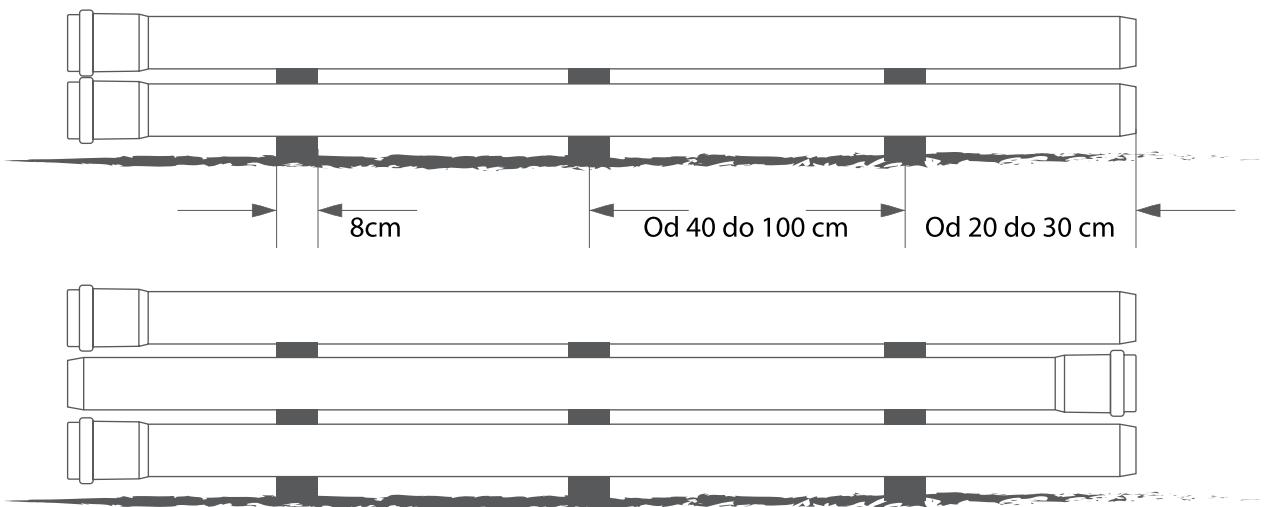

Wooden beams for underlying pipes should not be narrower than 8 cm and the thickness should not be thinner of 5 cm.

Axial spacing between the beams depending on the diameter and the length of the pipes ranges from 400 to 1000 mm, while the pipe overhang also depending on the diameter and length of the pipes also varies from 200 to 500 mm.

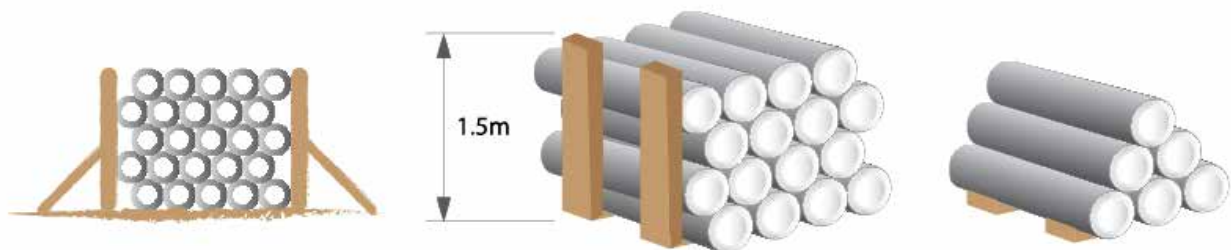



4 INSTALLATION

INSTALLATION AND CONNECTION

i Peštan's pipes and fittings are installed in accordance with EN 12056 Gravity drainage systems inside buildings.

! If there is a specific regulation within certain countries, which deviates from the norms mentioned, be sure to consult Peštan before installing.

4.1 Types of pipelines

To properly comprehend the connection and installation of interior installations for drainage of used water is necessary to explain the types of pipelines, which are part of a system for drainage of water use. The main classification of pipelines is as follows:

Connecting line from building to the street

This connection line is a line that leads from the building to terminal on a street circuit. It should be as short as possible and straighter.

Connecting line for the places where water is flowing

Connecting line is a pipeline to connect the pouring places (VC cup, bidet, sink, ...). Diameter of pipeline defines a number and type of the pouring places to join him. Connecting cables are mainly installed in grooves, in the walls and floors and closed with mortar or sleeve. The lines of this type can be installed in specially designated channels and can be closed by prefabricated elements, allowing easier access to the pipeline system when changing. Connecting lines also can be hung under the plate, that means for the ceiling of the room, which is located below, via clamps. There is another way of installing the connecting piping, which is mounting in cavity walls (plaster sandwich walls) and hanging by clips for constructive elements of sandwich walls. Connecting lines must not be longer than 3 m and must have a fall of minimum 3%. Connecting seats with the casting pipeline is realized via a siphon to prevent the return of odors from the sewage network. Connecting lines should be as short as possible and straighter.

The vertical line ("vertical")

The vertical line is placed vertically (so it got its name) and its purpose is to connect the first type of connecting lines with a second type of connection line. Peštan recommends the use of non-return valves at the connection places. Scheme of non-return valve installation is given on page n.20. Lines of this type are usually placed inside the walls and closed with mortar or placed in channels, relying on clamps. Placing pipes in the trench allows easier access to the pipeline for maintenance. In the case of plastic piping connections between the vertical line and the connection line is realized through two elbow of 45°. In buildings with more than three floors, cascade is installed to vertical pipe in order to reduce water consumption. Cascade is performed so as to draw the line elbow angle of 90° in the length of 250 mm, than it comes back in the vertical direction by elbow at an angle of 90°. Before elbow, reducer is being installed and after restoring water into vertical direction and by reducing piece returns to its original diameter. In this way, excessive force of water is avoided which would occur at the connecting point of the vertical and the connection line.

The vertical line should have a ventilation hole at its highest point. Peštan can offer venting device, which helps the unpleasant smells to go out through the hole that is outside. Ventilation of vertical line can be: primary and secondary.

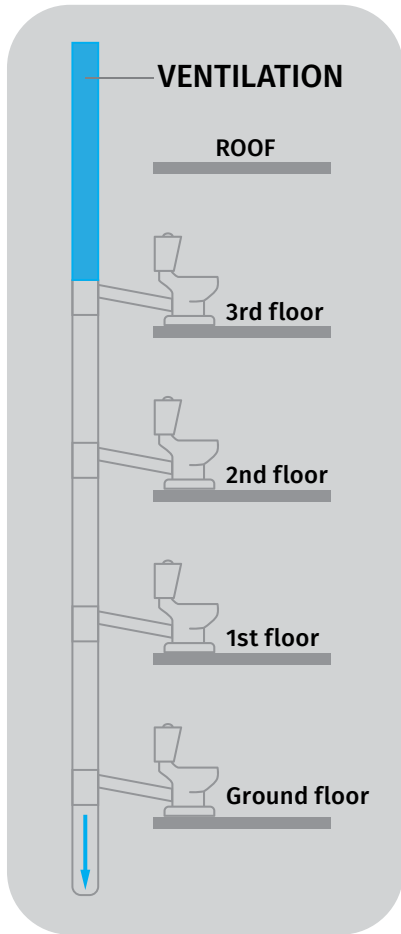

Display of the vertical with primary ventilation

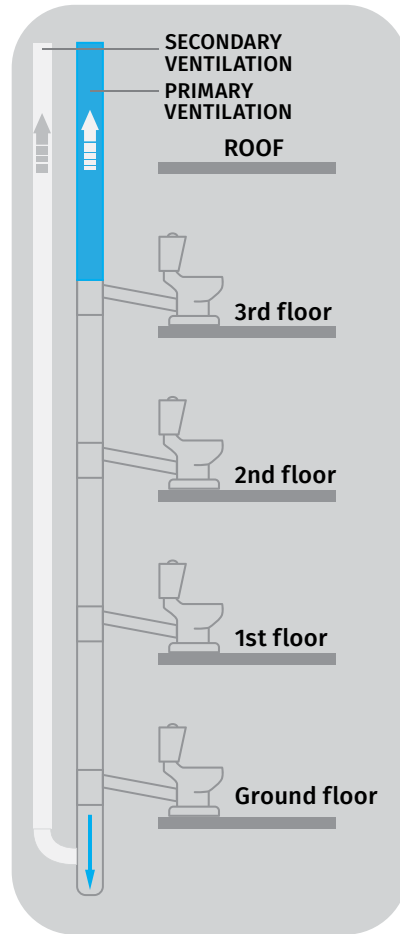

Display of the vertical with secondary ventilation

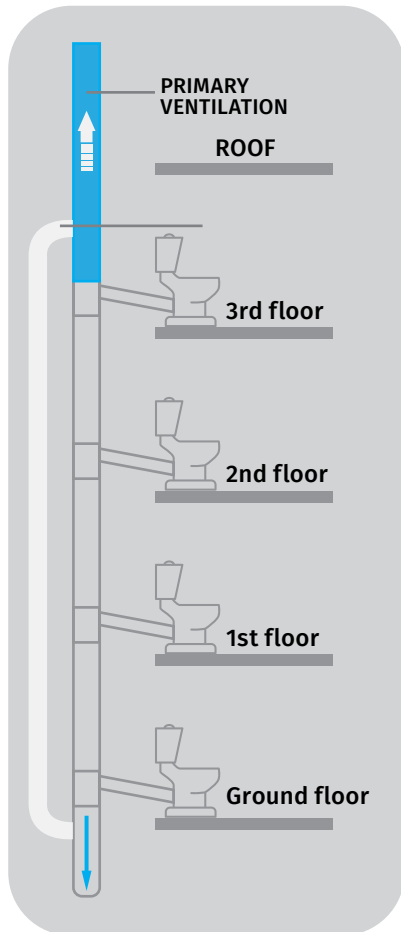

Display of the vertical with secondary ventilation

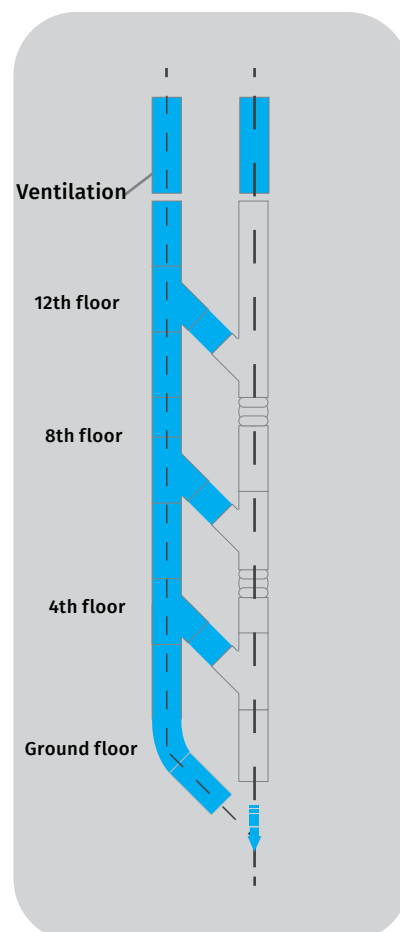

Ventilation in tall buildings



4.2 Pipes connecting

Elements of PP internal sewerage are connected by sockets and rubbers, which enables waterproof elements connection. Gluing pipes is not recommended. All pipes and fittings have at least one socket on the end. Pešťan has also the pipes with 2 sockets on offer. Pipes without sockets can be connected by double sockets and sleeve sockets. Pipes can be cut by using a special blade for pipe or hand saw blades with fine teeth, as shown on the picture below.



Fitting cannot be cut



Cutting pipes has to be done perpendicularly to pipe axis. The cut end of the pipe must be cleaned and skew. Skew of end of the pipe that was cut is achieved by fine sandpaper or a fine rasp. There are special tools for cutting, which during the cutting make a fine shape of the end of pipe. The table below shows the dimensions of the slope of pipe end.



Use all safety precautions

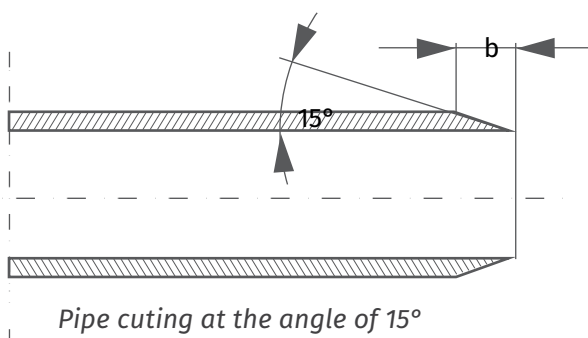

Pipe cutting at the angle of 15°

		Slope length						
DN	32	40	50	75	90	110	125	160
b(mm)	3,5	3,5	3,5	3,5	4,0	4,5	5,0	6,0

Review of required length of pipe diameter slope

After preparation of cut pipe or connecting fabric pieces without cutting, it is required to do next:

1. Clean a socket and flat part of a pipe. Cleaning should be done by dry or damp cloth.



Display of cleaning the pipe ends

2. After cleaning of pipe, condition of sealing elements should be inspected.



Display of sleeve with sealing rubber band

3. After cleaning and checking a condition of sealing elements, the flat end of the pipe should be lubricated. Pešťan's lubricants are recommended for this purpose. Lubricants based on oil, cannot be used. Socket and rubber seal should be dry and clean and they are not coated with a lubricant.



Display of lubricant applying.

4. After using a lubricant at the flat part of a pipe, it should be inserted into socket. Than mark entry depth and pull out a pipe cca 10mm. In this way a free working space is left while thermal dilatation. When working with pipes of max 2m length, pulling out the pipes for 10mm is quite enough. In case of using longer pipes (4m for example), lyre should be performed or to accept dilatations by changing the direction- in that case, flat ends are completely inserted into sockets.



Review of regularly inserted pipe into socket.

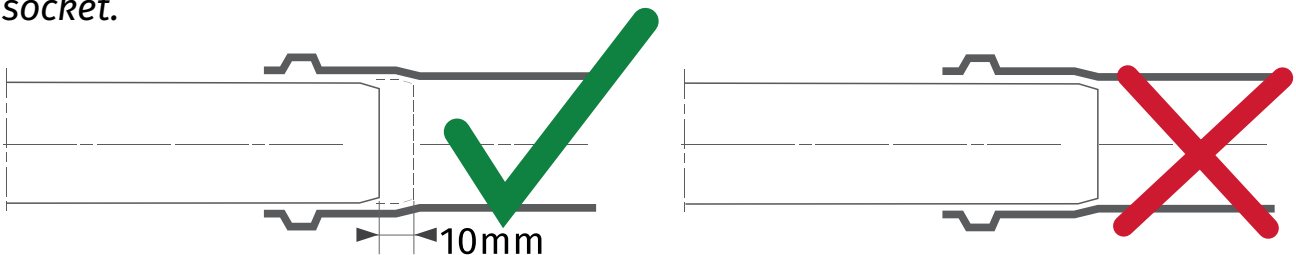

4.3 Connecting pipes and fittings

When installing pipelines, comes to cutting pipes which results in the appearance of the remains of the pipe which don't have sockets (pipe smooth on both sides). The figure below shows the way of connection pipeline with sleeve sockets and pipes without sockets. In this case the pipe without socket that is installed between the two connectors must have a minimum length of twice the nominal diameter ... For example, if the diameter is 160mm, than the minimum length of pipes without socket must be 320mm.

Also, while installing pipeline, where there are remains of pipes without socket, it should be noticed that length of the remains shouldn't be more than 3m. For such an installation, it is required to ensure enough quantity of sleeve sockets and double sockets, and certain quantity of clamps with profiled rubber bands.

On picture below, a difference in installation of remains of pipes without socket, with double and sleeve socket. More about pipeline reliance during installation in the next section.

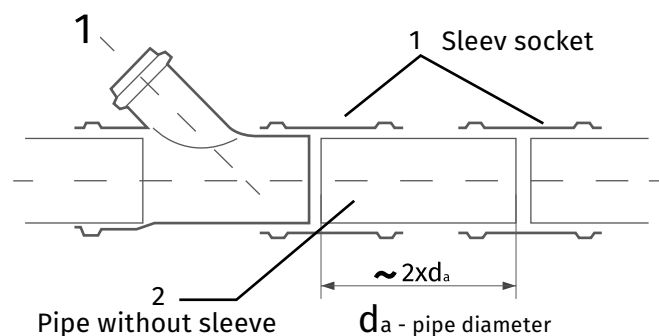



Also, while installing pipeline, where there are remains of pipes without socket, it should be noticed that length of the remains shouldn't be more than 3m. For such an installation, it is required to ensure enough quantity of sleeve sockets and double sockets, and certain quantity of clamps with profiled rubber bands.

On picture below, a difference in installation of remains of pipes without socket, with double and sleeve socket. More about pipeline reliance during installation in the next section.

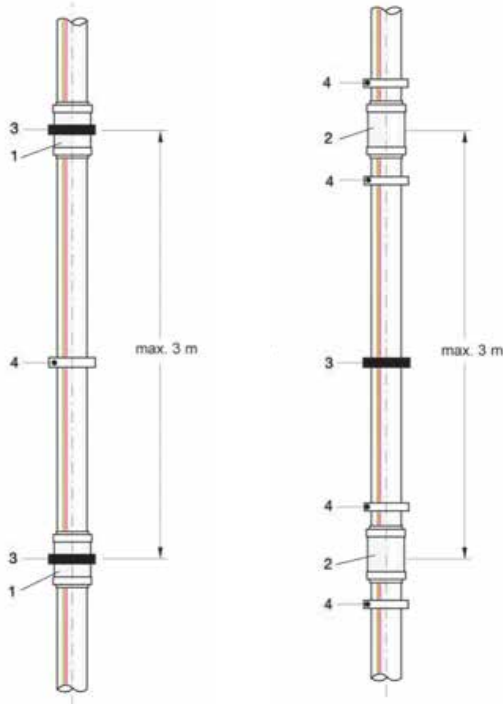

1. Double socket
2. Sleeve socket

3. Fixed point (holder)
4. Sleeve socket (holder)

4.4 Pipelines reliance

Pipelines reliance may be continuous or reliance in points. In case of installation of pipelines in the wall of the building, it is called continuous reliance, and pipeline reliance through the clamp is called pipelines in points.

Continuous pipeline reliance

This kind of reliance provides support for the pipeline along its entire length. These are pipelines placed inside the masonry walls and floor structures and panels. Penetrations through walls and grooves for the pipeline, which are closed by mortar must ensure installation of pipelines without voltage on pipeline and potential-free condition of the pipeline during the settlement of the building. Built-in pipeline, by the mode of installation should be protected from mechanical influences.

Full pipe elements must be placed in the breach. Connection between the pipes shouldn't be in the breach. In the case of polypropylene pipes for internal canalization, closing pipes by mortar can be done immediately after the assembly and installation of insulation, however it is not recommended to close the pipeline before checking water resistance, because in this way the immediate inspection of pipelines is disabled.

In case that the sewer pipe is near the water pipe, which transports warm water, both should be thermal isolated in accordance with applicable standards.

It's required with horizontal lines to support them throughout the length when installing in the floor, and at the same time the ability to compensate for temperature dilatation must be provided.

Pipeline reliance in points

When pipelines reliance in points, the pipeline is not supported throughout, and therefore terms of reliance of pipes, should be defined.

There are two types of point supports by way of reliance:

- Fixed (FT)
- moving (KT)

Fixed supports prevent the moving in all directions, and must be located below all sockets of the pipeline, ie in the case of pieces of pipes with both flat end, fixed bearing is installed on a double socket or sleeve socket. It should be noted that the fixed supports don't allow elongation of pipes, therefore it is necessary to position the supports in the way which enables that between two fixed support there is an element for compensation of the elongation of pipe (socket, if installed as described above or compensating element if the dilatation can not accept by space left in the socket).

Recommended spacing of holders		
DN	For horizontal pipeline (m)	For vertical pipeline (m)
32	0,50	1,2
40	0,50	1,2
50	0,50	1,5
75	0,80	2,0
90	0,95	2,0
110	1,10	2,0
125	1,25	2,0
160	1,60	2,0

Display of recommended spacing of supports for piping according to pipe diameter, distances are related to supports in general, while the preference for fixed or sliding support is performed according to the aforementioned criteria.

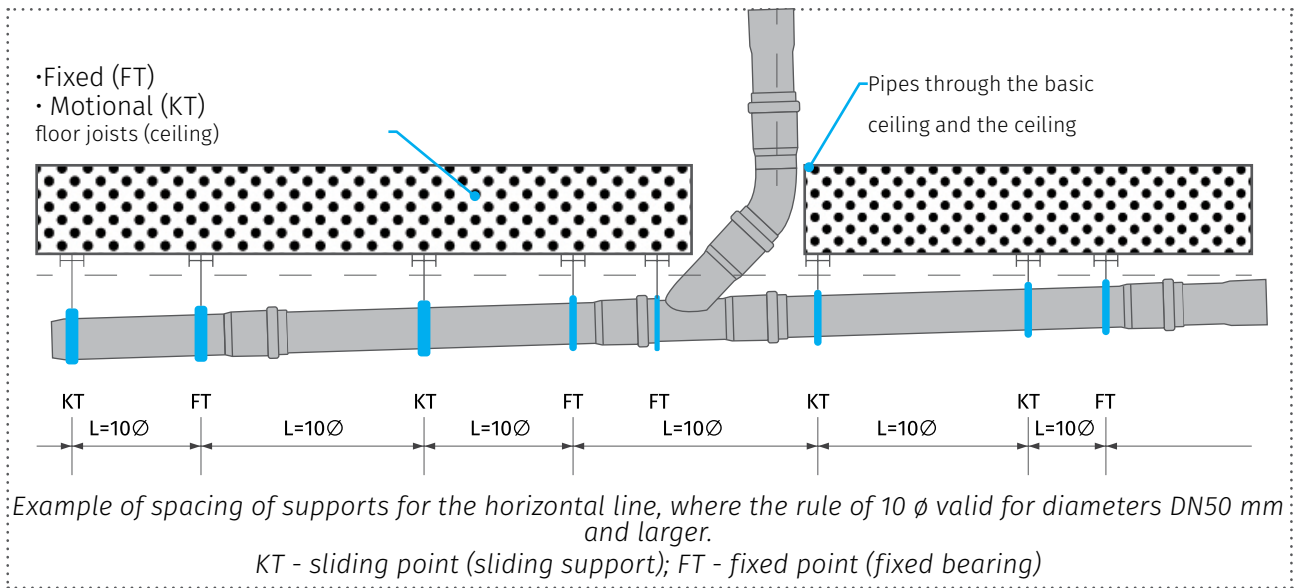

4.5 Pipes through the ceiling

Pipes through the basic ceiling and the ceiling must be soundproof and waterproof. The use of a KGF pieces for pipes through the ceiling is recommended, in order to ensure waterproofing of the joint. When through floor joists of smaller diameters, the waterproofing can be provided with mineral fiber, PP insulating foam or bitumen.

In case of need the security of the spread of fire, there are special measures that can be taken about it. It is possible to set the pipe in refractory sleeves, these sleeves are placed on the side of a mezzanine structure where a higher risk of fire.

4.6 Installing pipes in concrete

HT (PP) pipes Peštan can be installed without problems in the concrete, if one takes into account the longitudinal dilatation. When watering pipes in the concrete should be well secured, to prevent a relocation of the pipeline during the installation of concrete. It should also be ensured and pipe joints protective tape to prevent leakage of cement to seal elements.

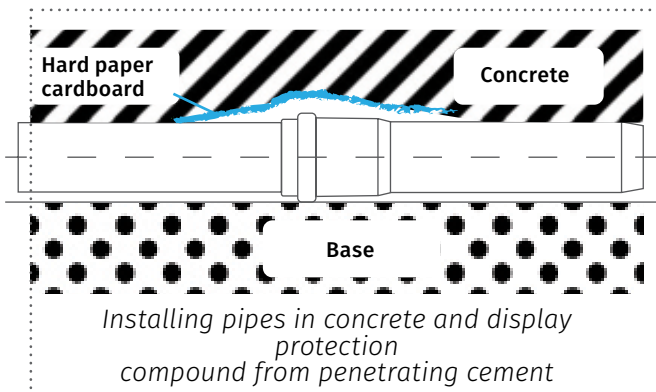

4.7 Installing devices to prevent flooding in buildings – Non-returnable valve

Non-return valves are installed in pipelines where there is a possibility of returning water from the street sewage in the building due to the increase of water in the sewage system and to prevent the entry of rodents and other animals through sewer pipes. As previously stated Pestan recommends the use of non-return valves on the connection of vertical lines on the connection line.



Non-return valves are fitted with an automatic closing flap in the flow of water from suprotkog direction in relation to the intended flow of water.

The basic postulate of installation

- Non-return valves are installed in smaller manholes easily Available for cleaning the device.
- When cleaning do not use objects with sharp edges.
- The maximum allowed drop when setting the check valve is 2%.

The following figure shows the installation scheme of non-return valve.

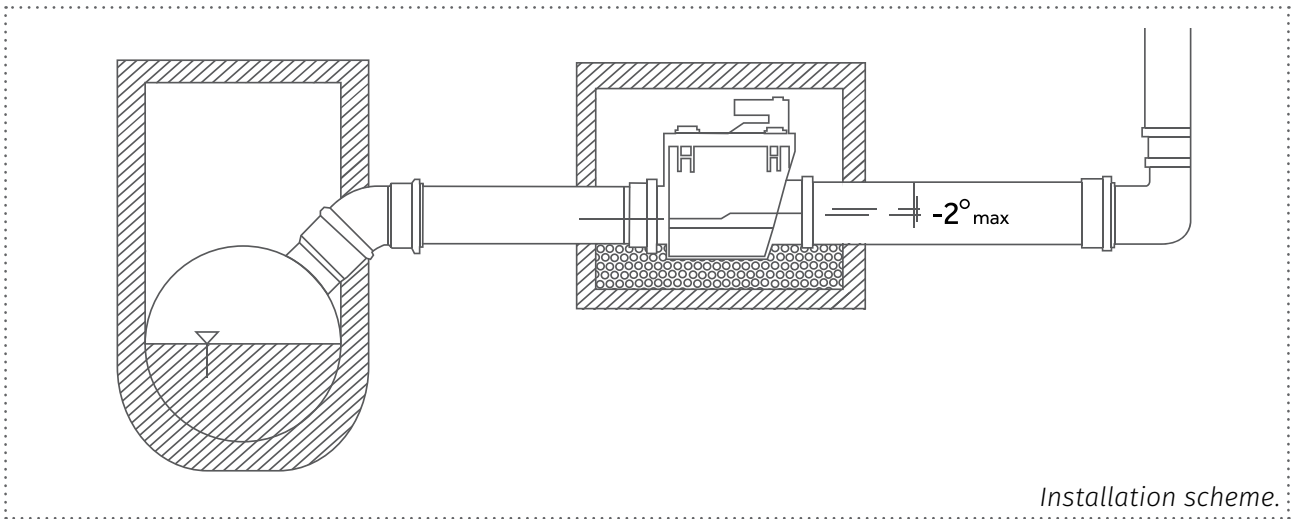

4.8 Measures to reduce noise

According to DIN 4109 noise resulting from pipeline, built-in sound-protected areas should not exceed 35 dB. The aforementioned reasons, the pipes should not be visibly guided in these areas. The pipes are led through the designated channels, if the wall surface weight greater than 220kg / m². Further noise reduction is achieved by using clamps with rubber inserts and using the plastic plugs for the fastening clamp to the wall. In the case that these measures do not bear fruit in the required extent, we recommend using Pešťan S LINE (low-noise) pipe systems.

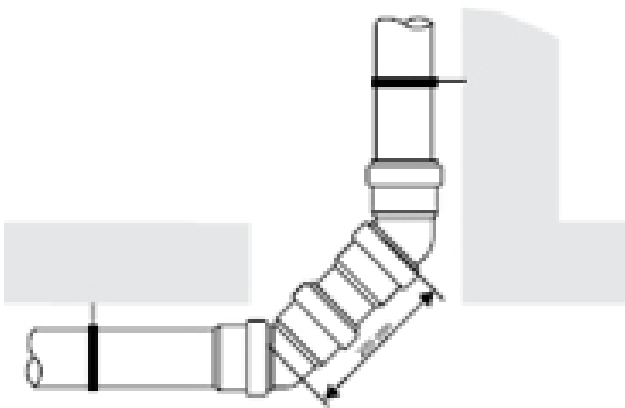

*Display of transition from vertical in horizontal line
(for zones of low permissible noise)*

4.9 Firefighting measures



Behavior of Pestan's HT (PP) pipes and fittings during the fire is fully in accordance with DIN 4102, under which are classified in class B2 (normal flammability class). Preventive fire protection that prevents the penetration of smoke and gases through the pipe insulation is an absolute obligation for each multi-storey building. According to the latest European standards, when pipelines cross through walls and floor structures it is necessary to use special clamp that prevents the spread of fire through the pipeline to other rooms in the house. Always use a tested and proven suppliers.



In cases when a fire occurs, a plastic tube under the influence of temperatures become soft and deformed. At the same time, at temperatures greater than 150 ° C, special fire protection laminate expands and increases its volume by up to 10 times. When spread within the metal part clamps, pressure laminate tube, around which the clamp is set, pressing up to 10bar. As a result of this pressure, in just a few minutes, fire laminate fully squeezes the plastic pipe, sealing thus breach the walls or floor construction. This leads to preventing the spread of flames and smoke through the pipes inside buildings, between rooms.

When installing the fire protection clamp in place pipe penetrations through the floor construction should know that the clamps can be installed during construction or later, after building.

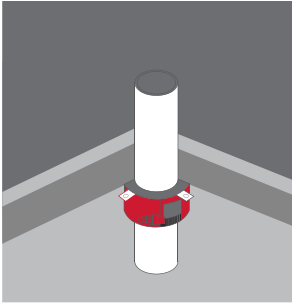

Installation of fire collars for mezzanine structure (during construction)

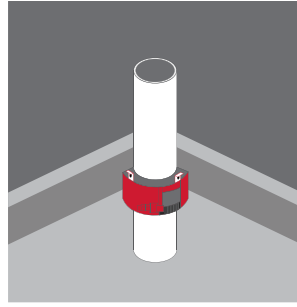

Installation of the sleeve to the basic structure (after construction)

When installing the fire protection clamp in place pipe penetrations through walls is necessary to install two clips (on both sides of the wall).

As for the mounting clamps penetration sealing angle, it should be noted that such a clamp is installed only on pipes through ceiling joists..

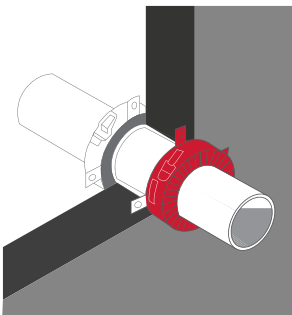

Installation of fire collars on the walls

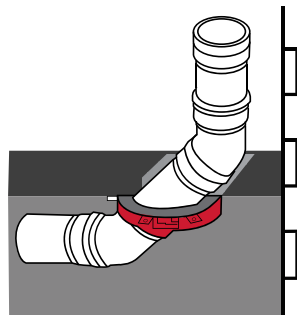

Mounting angle fire collars (only to basic ceiling)

4.10 Testing of pipelines



Testing of internal sewage forking can be divided into three categories:

- technical inspections,
- Test water resistance
- Test on gas resistance

The pipeline must not overlap prior to the execution of the test, all connections must be visible and clear. All openings must be temporarily closed during the test water resistance. The water with which the watertightness is tested should be dry. Overpressure testing water tightness ranges from a minimum of 0.03 bar to maximum 0.5 bar. Tightness test takes an hour. Criteria for passing the test water resistance is to not lose more than 0.5 liters / hour for every 10 m² of the inner surface of pipelines.

The pipeline is tested after assembly and connecting the casting elements and tested in segments. The segments are isolated by audit openings. It should be borne in mind that the greatest pressure occurs at the lowest point segment of the pipeline, which is being tested, and that took the place of the maximum allowable pressure of 0.5 bar . Installation of fire collars for mezzanine structure (during construction) Installation of the sleeve to the basic structure (after construction) The obligation of every builder is to make a record rehearsals pipeline and under these conditions, the warranty provided by the company Pestan.



Observe local regulations regarding the prevention

And localization of fires inside buildings.





5 NOISE REDUCTION

Sewage usage

Pestan S LINE pipes and fitting are installed in accordance with EN 12056 gravitational drainage system inside of buildings. If a special regulation exists in other country and is different than norm it is necessary to consult Pestan about it before the installation. In every area of edification sound isolation is every day more and more important. The pipe lines that transport fluids are one of the most frequent noise sources in buildings.

Both types of noise can be reduced to a minimum in different ways. Airborne noise is reduced by producing the pipes and fittings in special manner of special materials with special mineral additives or by optimizing the usage of fittings on spots where pipelines change direction. On direction changing spots it is recommended to use the elbows 45° and a pipe 25mm instead of an elbow 87.5°, so the level of noise made by flow and direction change can be reduced to maximum.

5.1 Noise reduction measures

There are 2 types of noise differed by what brings it:

- Airborne noise
- Structure-borne noise

Airborne noise is transmitted by air, and it comes from within the pipeline, it is the consequence of the fluid flow inside of the pipes. Pestan systems with its special design are limiting this noise level by keeping it inside the pipe.

Structure-borne noise is transmitted over the object walls. Vibrations occur during the fluid flow trough the pipe and fittings over the clamp and onto the building walls making irritating noise. With using the right clamps with profiled rubber of known producers and with proper installation of Pestan system of low noise pipes and fittings, this type of noise is reduced to a minimum.

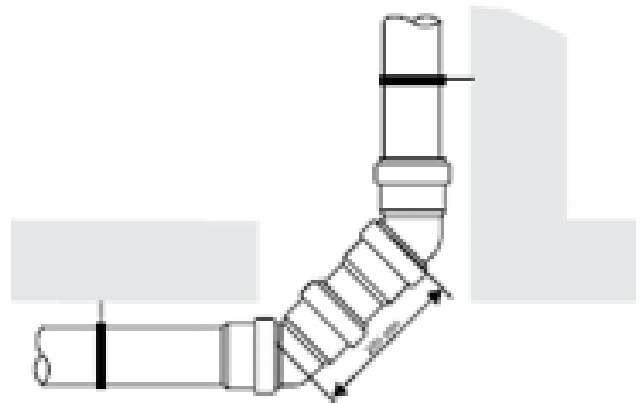

*The transition from a vertical to a horizontal line
(For zones of low allowable noise)*

Structure-borne noise is decreased by properly installing the pipeline with quality clamps with profiled rubber on (fixed points) also by optimized tightening of clamps (sliding spots).

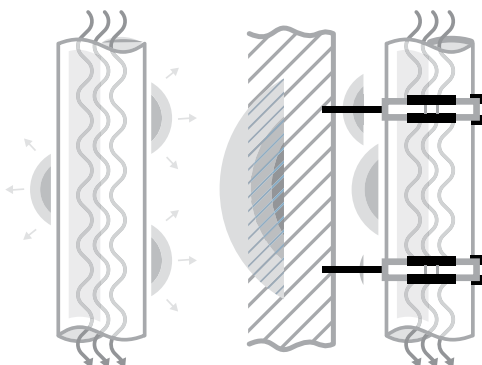

*Buka koja se prenosi
vazduhom (Airborn noise)*

*Buka koja se prenosi preko zidova
objekata (Structure-borne noise)*



Display of loose and tight clamps on pipes

5.2 Lab testing of sound isolation

To certify efficiency of sound isolation, system of pipes and fittings for house sewage Pestan Low Noise system is sent for testing to german Fraunhofer institute for construction physics.

Testings are made by EN 14366 norm (Laboratory measurement of noise from waste

water installations) and by DIN 4109 (Sound insulation in buildings – Requirements

and verifications), according to which the noise level must not surpass 35dB (A) in apartment building that require greater sound isolation.

Testings are made by EN 14366 norm (Laboratory measurement of noise from waste

water installations) and by DIN 4109 (Sound insulation in buildings – Requirements

and verifications), according to which the noise level must not surpass 35dB (A) in apartment building that require greater sound isolation. Testing is made under the flow 1.0 / 2.0 and 4.0 L/sec.

Test made with Pestan Low Noise pipe system has proven much better results of noise isolation than any other regular HT PP

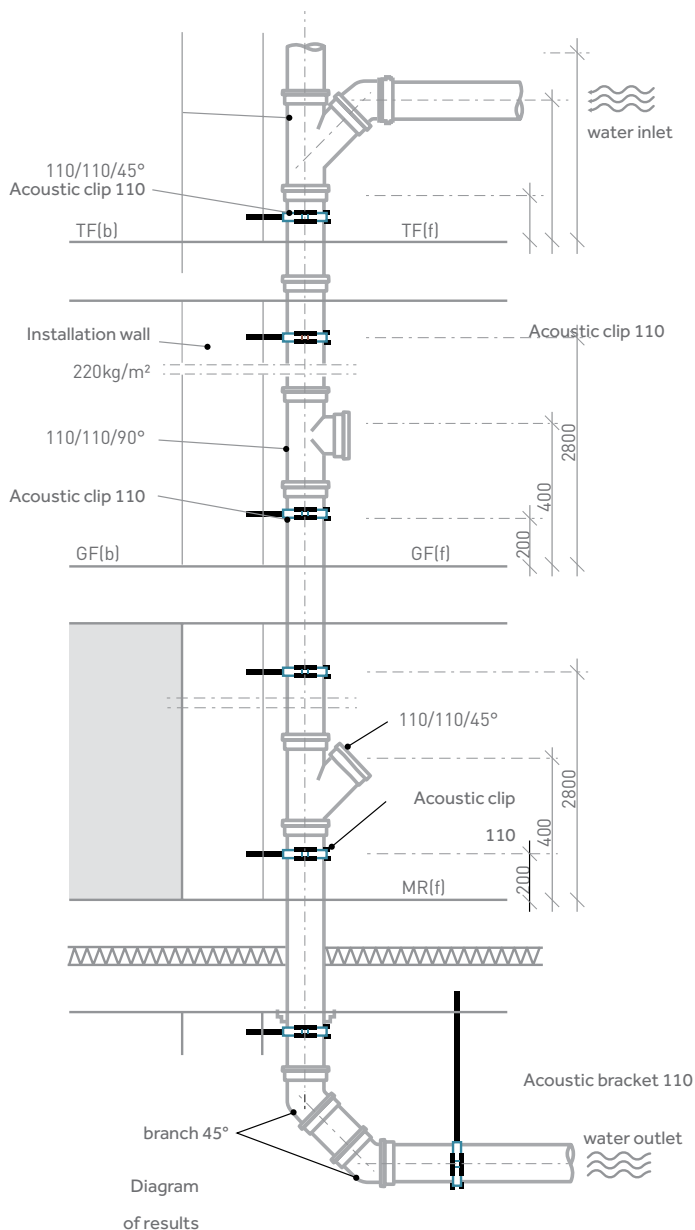

Display of system Installation in the Fraunhofer Institute

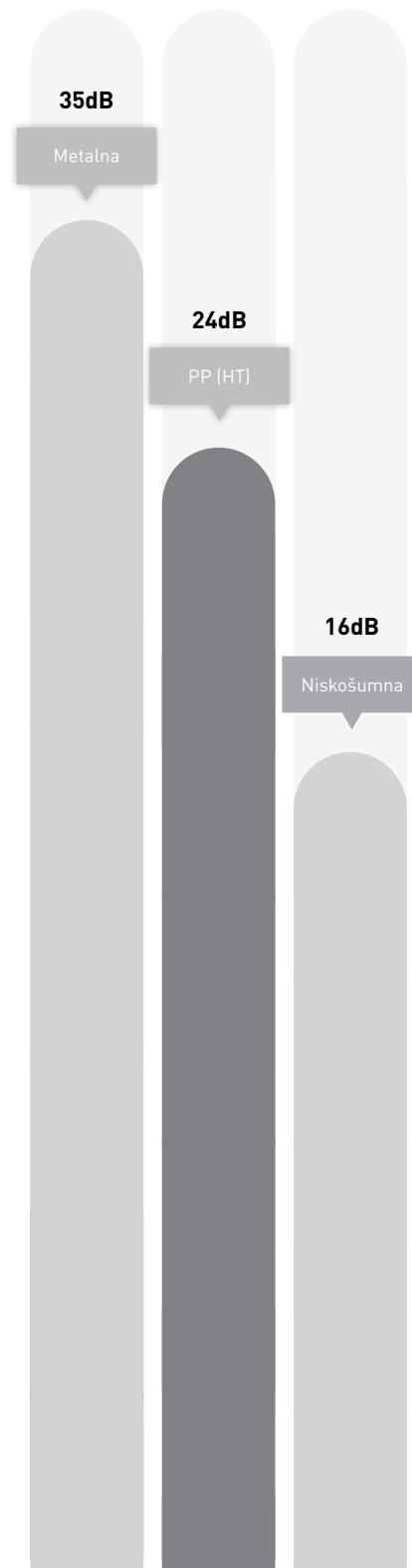



Source: LSC,A [dB(A)] Fraunhofer test report P-BA 93/2016e

Efficiency confirmation of elimination of fore mentioned problems of noise inside of pipe systems Pestan emitted by Fraunhofer, where by measuring was established that level of noise generated inside of Pestan pipe system is 24dB (under the fluid flow 2l/s(DN110)). Pestan HTPP pipes are wanted in buildings where noise level reduction is required on minimum, such as hospitals, schools, libraries, dormitories etc.)

Institution for testing, supervision and certification, officially recognized by the building supervisory authority. Approval of new building materials, components and types of construction.

Director:
Prof. Dr. phil. Lothar
Prof. Dr. Klaus Peter Seifried

Test Report P-BA 93/2016e

Determination of the Acoustic Performance of a Wastewater Installation System in the Laboratory

Client: Pestan D.O.O.
T300 Kaplana 189
Bukovica, 34300 Aradjevac
Serbia

Test object: Wastewater installation system consisting of plastic pipes and fittings "Pestan Standard" (manufacturer: Pestan) with pipe clamps "Bismat 2000" made by Wälzlager.

Content: Results sheet 1: Summary of test results
Figures 1 to 3: Detailed results
Figures 4 and 5: Test set-up
Annex A: Measurement set-up, noise excitation, acoustic parameters
Annex E: Evaluation of measurements
Annex F: Description of the test facility
Annex V: Assessment according to VDI 4100

Test date: The measurement was carried out on April 22, 2016 in the test facilities of the Fraunhofer institute for Building Physics in Stuttgart.

Stuttgart, May 8, 2016

Responsible Test Engineer: Head of Laboratory:

M.Sc. B. Kahlert M.Eng. Dipl.-Ing. D.H.S. Ollar

The test was carried out in a laboratory, accredited according to DIN EN ISO/IEC 17025:2005 by DAkkS. The accreditation certificate is D-PL-11340-11-01.

Any publication of this document in part is subject to written permission by the Fraunhofer Institute for Building Physics (IBP).

Fraunhoferinstitut für Bauphysik
Nobelstraße 12 · D-70569 Stuttgart
Telefon +49 (0) 71 47 0-0
Telefax +49 (0) 71 47 0-3395
www.ipb.fraunhofer.de

Prüfstelle Bautechnik und Schalleistungsversuche
Rutenbergstraße 12 · D-70569 Stuttgart
Telefon +49 (0) 71 47 0-3314, fax -1406
akustik@ipb.fraunhofer.de
www.ipb.fraunhofer.de/www/pruefstellebautechnik.de

Results achieved during the test with Pestan HTPP pipe system (behind the wall of 220kg/m² and minimal thickness of 115mm plus mortar), a with different flows they gave the following diagram.

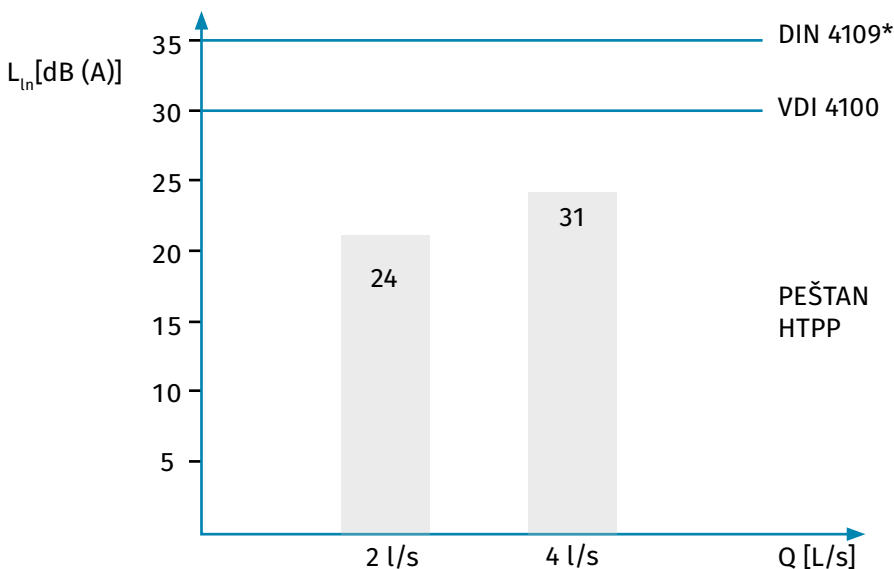

The measurement results with commercial pipe clamp, "BISMAT 2000", behind a wall in the basement.

Ln – noise level dB(A)

Q – flow rate L/sec

* - the maximum allowed noise level by DIN 4109

5.3 Level of sound isolation and classification

According to VDI 4100 there are 3 degrees in sound isolation, depending on the purpose of object in which the pipes are installed:

*Level 1 DIN 4109 corresponds to 30dB (A)

*Level 2 corresponds to 25dB (A)

*Level 3 corresponds to 20 dB (A)

VDI level of sound isolation and class

*Level 1 - Family house

*Level 2 - apartment building and offices

*Level 3 - Hotels, hospitals, libraries, living complexes



Family house
Level I of sound isolation



Apartment building and offices
Level II of sound isolation

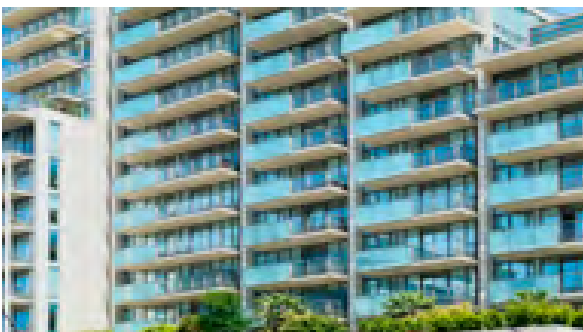

Hotels, hospitals, libraries, living complexes
Level III of sound isolation





6 USAGE

USAGE OF PIPELINES

Pestan HT (PP) program is primarily designed for internal distribution systems for the evacuation of used water in residential buildings. Because of the areas of application of these systems, as part of this chapter will be explained by way of sizing the interior times with water drainage water use residential buildings.

Hydraulic design of culverts consists of two parts:

- Empirical part
- Calculation

Empirical part

The empirical part deals with the dimensioning of the pipe horizontal fork and collecting the used waters from the casting, ie, the connecting cables. This part of the calculation is done empirically because of the frequency of a large number of factors that the water binding capacity of influence, ie, variability in flow of waste water, the variability of the flow rate naravnornost, diversity sanitary equipment (pouring seats), variability of the number of people using the facilities, a variety of long time use building and the presence of air and gases in the network. The following table shows the diameter by area of use



Diameter of pipe (mm)	Place of use
DN 50	1. only in the upper branches of the arrester for connecting one to two sinks arrester
DN 75	1. In the upper branches of the arrester as a continuation of the confluence of three or more sinks 2. As an offshoot of the arrester stack for bathroom and shower 3. As a vertical upper surge sinks and urinals
DN 110	1. Vertical upper arrester for latrines 2. Branch vertical arrester for latrines and pomijare 3. As a horizontal underside of the upper surge arrestors (vertical) of detention for washing and kitchen wastewater 4. As the upper vertical arrester of toilets in basement walls and under the floor of the basement to the horizontal lower arrester horizontalnog donjeg odvodnika
DN 125	1. Vertical arrester of rainwater 2. Eventually as the upper vertical arrester for a very large number of the closet 3. As the lower arresters compound rain pipe drain
DN 160	1. . The upper arrester (vertical) for a large number of group lavatory on the floors 2. As an offshoot of the upper arrester for the group urinals in a row 3. Horizontal lower sink for all of the above urinals 4. As a major arrester home network

Calculation

The computational part refers to the determination of the diameter of the compound's main distribution channel (vertical) with street, ie. Computing part refers to the budget of connecting cables. Calculation of the connecting line is also validated the main internal waters, ie vertical water for buildings. For this purpose it is necessary first to determine the

amount of wastewater flow in liters per second (l / s). The quantity wastewater flow affect the volume of consumption of drinking water in the house, and the volume of water consumption is influenced by: type, type of building, number of occupants, number and type of sanitary facilities. The following tables presents information about germ wastewater for a variety of building and sanitary kits.

The volume of water consumption (production waste water)		Consumption of one resident per day (1 / day)	
In temperate (small) water consumption		50-70	
When sufficient (high) water consumption		70-150	
When plentiful (large) water consumption		150-500	
<i>Determination of the quantity of waste water according to the number of tenants</i>			
Type of sanitary facility	From one use (l)	Per hour (l)	Per day
WC sa visokim kotličem	7,0	According to frequency of use	according to usage period
washbasin	3,0		
urinal	4,0		
Bathtub	180,0		
shower	70,0		
bidet	3,0		
basins	20,0		
the fountain in the kitchen		180,0	
sink		250,0	
<i>The quantity of wastewater production by type of sanitary facilities</i>			

Type of sanitary facility	duration of use
One use of toilet	10-15 min.
One showering	45 min.
One bath	60 min.
One wash	5-10 min.
The use of the urinal	1-3 min.
One use of the bidet	3-5 min.
<i>The duration of use of sanitary appliances</i>	



Type of building	Type of device	Production of one person per day
Residential buildings	with normal sanitary devices	125 - 150
	with exceptional sanitary devices	150 - 300
Social buildings	with normal sanitary devices	80 - 120
	hotels	250 - 400
Public buildings	Schools with the necessary device	12
	Schools with the complete device	21
	Various government offices with normal device	15
	Hospitals (per bed)	250 - 500
	Sanatoriums (per bed)	230 - 400
	Ambulance (per patient)	6
	Kindergarden (per kid)	50 - 75
	With necessary device (per worker per shift)	10 - 25
With necessary device (per worker per shift)	10	
<i>The amount of waste water by type of building</i>		

name	Unit of consumption	Liters per day per unit	Liters per hour per unit
canteen	From making one meal	10 - 25	-
canteen	From one tap	-	250
public baths	From one bath	125 - 180	-
public baths	From one tap	-	500 - 800
laundries with mechanical drive	From one kg of dry laundry	60 - 75	-
Laundries with manual drive	From one kg of dry laundry	35	-
public restroom	From one toalete place	350 - 600	-
Public urinals with constant rinsing	From one urinal place	-	200
Buffets	From one tap	-	120
Taverns	From one tap	-	300
Pharmacies	From one tap	60	-
laboratories	From the table with 5-7 sits	-	1500 - 2000
medical offices	From the time of receipt of patients	-	30 - 40
berberine	From one work table with washbasin	75	-
Stables	From one car washing	700	-
	From one horse	50	-
	From one ox	40	-
	From one pig	13	-
	From one sheep	8	-
<i>Waste water for economic buildings and stores</i>			

Because for using above given table is necessary to know the exact user habits and beause the calculation on this way is complicated, we suggest using the methods described below.

Calculation of dimensioning of the connecting line according to Saming

To determine the diameter of the connecting line it is needed, of the total daily amount of wastewater, to calculate the flow rate of wastewater per second. For this purpose the method of the calculation by

Saming can be useful. With this method comes a new set of tables. The following table shows the amount of effusion of individual sanitary facilities, reduced to the equivalent factor K.

Type of the outflow object	Equivalent K	Outflow amount q''	
		u lit./ sec.	u lit./min.
Faucet	1	0,33	20
Toilet with high rinsing	3,6	1,20	-
Toilet with low rinsing	6,0	2,00	-
Urinal	0,5	0,17	10
Washbasin- bathroom sink	0,5	0,17	10
Kitchen sink	2,0	0,67	40
Bathtub	2,0	0,67	40
Shower	0,7	0,22	14
Bidet	0,5	0,15	10
Small faucet	0,25	0,08	5
<i>Outflow amount of sanitary objects</i>			

For unit is taken outflow from one water faucets of $\varnothing 1/2$ ". The amount of outflow is calculated in liters / sec. In another table are given the percentages of

approved coincident outflow equivalent accessories for adequate number of the same and according to purpose of building. This number is indicated by P.

Residential buildings				Social buildings			
NK	P	NK	P	NK	P	NK	P
do 10	19,8	do 160	5,0	do 10	14,3	do 100	4,5
do 15	16,2	do 180	4,7	do 12	12,9	do 120	4,1
do 20	14,0	do 200	4,4	do 14	12,0	do 140	3,8
do 25	12,6	do 250	4,0	do 16	11,2	do 160	3,6
do 30	11,5	do 300	3,6	do 18	10,5	do 180	3,4
do 35	10,6	do 350	3,4	do 20	10,0	do 200	3,2
do 40	9,9	do 400	3,1	do 25	9,0	do 250	2,8
do 45	9,4	do 450	3,0	do 30	8,2	do 300	2,6
do 50	8,9	do 500	2,8	do 35	7,6	do 350	2,4
do 60	8,1	do 600	2,6	do 40	7,1	do 400	2,2
do 70	7,5	do 700	2,4	do 45	6,7	do 500	2,0
do 80	7,1	do 800	2,2	do 50	6,3	do 600	1,8
do 90	6,6	do 900	2,1	do 60	5,8	do 700	1,7
do 100	6,3	do 1000	2,0	do 70	5,4	do 800	1,6
do 120	5,7	do 1500	1,6	do 80	5,0	do 900	1,5
do 140	5,3	do 2000	1,4	do 90	4,7	do 1000	1,4

Percentage of concurrent outflow of the same facilities; NK-product coefficient K with the same number of outlet facilities N.



Using the data in these tables and the number outflow places, collected by types and groups of verticals, the second amount of effusion loading of the main house connecting pipeline is obtained. This quantity is calculated according to the formula:

$$Q_{sec} = \frac{N \times P \times q^n}{100}$$

Where are:

Q - second quantity of flow of waste water,

N - number of objects of the same type,

P - the percentage of simultaneous effusion the same objects and

qⁿ - quantity of effusion of individual objects in liters / second.

Example of calculating according to saming:

First we need to count all inlet objects of the same type, and then make a tabular review, as shown below:

Types of sanitary equipment	Number of equipment across verticals		The total number of the same equipment	The equivalent factor K for an equipment on the table	Of the factors K and N to the number of equipment which determines the percentage of P	The total number of equipment N	Percentage P simultaneous effusion of the total number of equivalent equipment	Quantity effusion qn Lit / sec. for appropriate equipment	The total quantity of effusion Q Lit / sec
	13	15							
The toilets (WC)	-	2	2	3,6	7,2				0,474
Sinks	-	2	2	0,5	1,0				0,067
Bathtubs	-	2	2	2,0	4,0				0,265
Small faucet	1	-	1	0,25	0,25				0,016
Kitchen sink	-	2	2	2,0	4,0				0,265
								Total Q=	1,087

Example of calculating

After determining the total quantity of waste water and flow rate in liters / second, access to the selection of the appropriate diameter of the hydraulic tables provided in the next section..

Selection of appropriate diameter is performed according to the following criteria:

- Main home line must be a minimum DN 160 mm
- Occasionally, during the day, it must have a speed of 0.7 m / s for self-cleaning pipes

Since HT (PP) Pestan program has no larger diameters from DN 160 mm, for the purposes of increasing the connecting line is recommended to use Pestan PVC pipe systems. Peštan's PVC product range is compatible with HT(PP) product range, therefore these two kind of pipelines can be combined.

In further table, the flow of the pipe HT (PP) DN 160 with different longitudinal falls is shown. If there is a request for a bigger diameter, you can find all details in PVC technical instructions, where you can find hydraulic table for PVC pipes.

For the flows for partial fulfillment of flow profile, please use hydraulic table 2.

First you need to determine flow through the pipeline, assume fall and find appropriate one by test of coefficients of fulfillment cross section. Take care that flow for the selected fall at complete fulfillment of profiles (Hydraulic Table 1) is greater than one which we seek.

DN (mm)	160		DN (mm)	160		DN (mm)	150		DN (mm)	160		DN (mm)	160	
Type of pipe	sdr41		Type of pipe	sdr41		Type of pipe	sdr41		Klasa cevi	sdr41		Type of pipe	sdr41	
<i>Hydraulic Table 1: different falls for HT (PP) pipes DN 160 mm k = 0.50</i>														
I (‰)	v (m/s)	Q (L/s)	I (‰)	v (m/s)	Q (L/s)	I (‰)	v (m/s)	Q (L/s)	I (‰)	v (m/s)	Q (L/s)	I (‰)	v (m/s)	Q (L/s)
0,1	0,092	1,672	4,9	0,719	13,034	9,7	1,018	18,471	19	1,433	25,989	28,6	1,762	31,965
0,2	0,134	2,437	5	0,726	13,169	9,8	1,024	18,568	19,2	1,441	26,127	28,8	1,769	32,078
0,3	0,167	3,031	5,1	0,734	13,303	9,9	1,029	18,664	19,4	1,448	26,264	29	1,775	32,190
0,4	0,195	3,533	5,2	0,741	13,436	10	1,034	18,760	19,6	1,456	26,401	29,2	1,781	32,302
0,5	0,219	3,977	5,3	0,748	13,568	10,2	1,045	18,950	19,8	1,463	26,537	29,4	1,787	32,414
0,6	0,241	4,380	5,4	0,755	13,698	10,4	1,055	19,138	20	1,471	26,673	29,6	1,793	32,525
0,7	0,262	4,751	5,5	0,762	13,828	10,6	1,066	19,325	20,2	1,478	26,808	29,8	1,799	32,636
0,8	0,281	5,096	5,6	0,769	13,956	10,8	1,076	19,509	20,4	1,485	26,942	30	1,806	32,747
0,9	0,299	5,421	5,7	0,776	14,083	11	1,086	19,692	20,6	1,493	27,075	30,5	1,821	33,021
1	0,316	5,728	5,8	0,783	14,208	11,2	1,096	19,873	20,8	1,500	27,208	31	1,836	33,294
1,1	0,332	6,021	5,9	0,790	14,333	11,4	1,106	20,053	21	1,507	27,340	31,5	1,851	33,564
1,2	0,347	6,301	6	0,797	14,457	11,6	1,115	20,231	21,2	1,515	27,472	32	1,865	33,832
1,3	0,362	6,569	6,1	0,804	14,580	11,8	1,125	20,408	21,4	1,522	27,603	32,5	1,880	34,098
1,4	0,376	6,828	6,2	0,811	14,701	12	1,135	20,583	21,6	1,529	27,733	33	1,895	34,362
1,5	0,390	7,077	6,3	0,817	14,822	12,2	1,144	20,757	21,8	1,536	27,863	33,5	1,909	34,624
1,6	0,404	7,319	6,4	0,824	14,942	12,4	1,154	20,929	22	1,543	27,992	34	1,923	34,884
1,7	0,416	7,553	6,5	0,830	15,061	12,6	1,163	21,100	22,2	1,550	28,120	34,5	1,938	35,143
1,8	0,429	7,780	6,6	0,837	15,178	12,8	1,173	21,269	22,4	1,558	28,248	35	1,952	35,399
1,9	0,441	8,001	6,7	0,843	15,295	13	1,182	21,437	22,6	1,565	28,376	35,5	1,966	35,653
2	0,453	8,217	6,8	0,850	15,412	13,2	1,191	21,604	22,8	1,572	28,502	36	1,980	35,906
2,1	0,465	8,427	6,9	0,856	15,527	13,4	1,200	21,770	23	1,579	28,629	36,5	1,994	36,157
2,2	0,476	8,632	7	0,862	15,641	13,6	1,209	21,934	23,2	1,585	28,754	37	2,007	36,406
2,3	0,487	8,833	7,1	0,869	15,755	13,8	1,218	22,097	23,4	1,592	28,880	37,5	2,021	36,654
2,4	0,498	9,029	7,2	0,875	15,868	14	1,227	22,259	23,6	1,599	29,004	38	2,035	36,900
2,5	0,508	9,221	7,3	0,881	15,980	14,2	1,236	22,420	23,8	1,606	29,128	38,5	2,048	37,144
2,6	0,519	9,410	7,4	0,887	16,091	14,4	1,245	22,580	24	1,613	29,252	39	2,061	37,387
2,7	0,529	9,595	7,5	0,893	16,202	14,6	1,254	22,739	24,2	1,620	29,375	39,5	2,075	37,628
2,8	0,539	9,776	7,6	0,899	16,312	14,8	1,262	22,896	24,4	1,626	29,498	40	2,088	37,868
2,9	0,549	9,955	7,7	0,905	16,421	15	1,271	23,053	24,6	1,633	29,620	40,5	2,101	38,106
3	0,559	10,130	7,8	0,911	16,529	15,2	1,280	23,208	24,8	1,640	29,741	41	2,114	38,343
3,1	0,568	10,303	7,9	0,917	16,637	15,4	1,288	23,363	25	1,647	29,863	41,5	2,127	38,578
3,2	0,577	10,473	8	0,923	16,744	15,6	1,297	23,516	25,2	1,653	29,983	42	2,140	38,812
3,3	0,587	10,640	8,1	0,929	16,851	15,8	1,305	23,669	25,4	1,660	30,103	42,5	2,153	39,044
3,4	0,596	10,804	8,2	0,935	16,956	16	1,313	23,820	25,6	1,666	30,223	43	2,166	39,275
3,5	0,605	10,967	8,3	0,941	17,061	16,2	1,322	23,971	25,8	1,673	30,342	43,5	2,178	39,505
3,6	0,613	11,127	8,4	0,946	17,166	16,4	1,330	24,120	26	1,680	30,461	44	2,191	39,734
3,7	0,622	11,284	8,5	0,952	17,270	16,6	1,338	24,269	26,2	1,686	30,579	44,5	2,203	39,961
3,8	0,631	11,440	8,6	0,958	17,373	16,8	1,346	24,417	26,4	1,693	30,697	45	2,216	40,187
3,9	0,639	11,594	8,7	0,964	17,476	17	1,354	24,564	26,6	1,699	30,814	45,5	2,228	40,411
4	0,648	11,745	8,8	0,969	17,578	17,2	1,362	24,710	26,8	1,705	30,931	46	2,240	40,635
4,1	0,656	11,895	8,9	0,975	17,679	17,4	1,370	24,855	27	1,712	31,048	46,5	2,253	40,857
4,2	0,664	12,043	9	0,980	17,780	17,6	1,378	25,000	27,2	1,718	31,164	47	2,265	41,078
4,3	0,672	12,189	9,1	0,986	17,880	17,8	1,386	25,143	27,4	1,725	31,280	47,5	2,277	41,298
4,4	0,680	12,334	9,2	0,991	17,980	18	1,394	25,286	27,6	1,731	31,395	48	2,289	41,516
4,5	0,688	12,477	9,3	0,997	18,080	18,2	1,402	25,428	27,8	1,737	31,510	48,5	2,301	41,734
4,6	0,696	12,618	9,4	1,002	18,178	18,4	1,410	25,569	28	1,744	31,624	49	2,313	41,950
4,7	0,703	12,758	9,5	1,008	18,277	18,6	1,418	25,710	28,2	1,750	31,738	49,5	2,325	42,166
4,8	0,711	12,897	9,6	1,013	18,374	18,8	1,425	25,850	28,4	1,756	31,852	50	2,337	42,380



Q/Qpp	h/d	v/vpp	Q/Qpp	h/d	v/vpp	Q/Qpp	h/d	v/vpp	Q/Qpp	h/d	v/vpp	Q/Qpp	h/d	v/vpp	Q/Qpp	h/d	v/vpp
<i>Hydraulic Table 2: Ratios of the amount of water flow and the flow velocity HT (PP) sewerage pipes in partial fulfillment profile</i>																	
0,001	0,023	0,17	0,045	0,141	0,52	0,21	0,309	0,80	0,51	0,506	1,00	0,805	0,701	1,08	0,955	0,856	1,05
0,002	0,032	0,21	0,05	0,149	0,54	0,22	0,316	0,81	0,52	0,512	1,01	0,81	0,705	1,08	0,960	0,865	1,04
0,003	0,038	0,24	0,055	0,156	0,55	0,23	0,324	0,82	0,53	0,519	1,01	0,815	0,709	1,08	0,965	0,874	1,04
0,004	0,044	0,26	0,06	0,163	0,57	0,24	0,331	0,83	0,54	0,525	1,02	0,82	0,713	1,08	0,970	0,883	1,04
0,005	0,049	0,28	0,065	0,170	0,58	0,25	0,339	0,84	0,55	0,531	1,02	0,825	0,717	1,08	0,975	0,894	1,03
0,006	0,053	0,29	0,07	0,176	0,59	0,26	0,346	0,85	0,56	0,537	1,02	0,83	0,721	1,08	0,980	0,905	1,03
0,007	0,057	0,30	0,075	0,182	0,60	0,27	0,353	0,86	0,57	0,543	1,03	0,835	0,725	1,08	0,985	0,919	1,02
0,008	0,061	0,32	0,08	0,188	0,61	0,28	0,360	0,86	0,58	0,550	1,03	0,84	0,729	1,07	0,990	0,935	1,02
0,009	0,065	0,33	0,085	0,194	0,62	0,29	0,367	0,87	0,59	0,556	1,03	0,845	0,734	1,07	0,995	0,956	1,01
0,01	0,068	0,34	0,09	0,200	0,63	0,3	0,374	0,88	0,6	0,562	1,04	0,85	0,738	1,07	1,000	1,000	1,00
0,011	0,071	0,35	0,095	0,205	0,64	0,31	0,381	0,89	0,61	0,568	1,04	0,855	0,742	1,07			
0,012	0,074	0,36	0,1	0,211	0,65	0,32	0,387	0,89	0,62	0,575	1,04	0,86	0,747	1,07			
0,013	0,077	0,36	0,105	0,216	0,66	0,33	0,394	0,90	0,63	0,581	1,05	0,865	0,751	1,07			
0,014	0,080	0,37	0,11	0,221	0,67	0,34	0,401	0,91	0,64	0,587	1,05	0,87	0,756	1,07			
0,015	0,083	0,38	0,115	0,226	0,68	0,35	0,407	0,92	0,65	0,594	1,05	0,875	0,761	1,07			
0,016	0,086	0,39	0,12	0,231	0,69	0,36	0,414	0,92	0,66	0,600	1,05	0,88	0,766	1,07			
0,017	0,088	0,39	0,125	0,236	0,69	0,37	0,420	0,93	0,67	0,607	1,06	0,885	0,770	1,07			
0,018	0,091	0,40	0,13	0,241	0,70	0,38	0,426	0,93	0,68	0,613	1,06	0,89	0,775	1,07			
0,019	0,093	0,41	0,135	0,245	0,71	0,39	0,433	0,94	0,69	0,620	1,06	0,895	0,781	1,07			
0,02	0,095	0,41	0,14	0,250	0,72	0,4	0,439	0,95	0,7	0,626	1,06	0,9	0,786	1,07			
0,022	0,100	0,42	0,145	0,255	0,72	0,41	0,445	0,95	0,71	0,633	1,06	0,905	0,791	1,07			
0,024	0,104	0,43	0,15	0,259	0,73	0,42	0,451	0,96	0,72	0,640	1,07	0,91	0,797	1,07			
0,026	0,108	0,45	0,155	0,263	0,74	0,43	0,458	0,96	0,73	0,646	1,07	0,915	0,803	1,06			
0,028	0,112	0,45	0,16	0,268	0,74	0,44	0,464	0,97	0,74	0,653	1,07	0,92	0,808	1,06			
0,03	0,116	0,46	0,165	0,272	0,75	0,45	0,470	0,97	0,75	0,660	1,07	0,925	0,814	1,06			
0,032	0,120	0,47	0,17	0,276	0,76	0,46	0,476	0,98	0,76	0,667	1,07	0,93	0,821	1,06			
0,034	0,123	0,48	0,175	0,281	0,76	0,47	0,482	0,99	0,77	0,675	1,07	0,935	0,827	1,06			
0,036	0,127	0,49	0,18	0,285	0,77	0,48	0,488	0,99	0,78	0,682	1,07	0,94	0,834	1,05			
0,038	0,130	0,50	0,19	0,293	0,78	0,49	0,494	1,00	0,79	0,689	1,07	0,945	0,841	1,05			
0,04	0,134	0,50	0,2	0,301	0,79	0,5	0,500	1,00	0,8	0,697	1,07	0,95	0,849	1,05			

7 INTERFERENCE

Resolving of interference

During exploitation, with any piping system there are the potential for interference. Interference in the case of sewage pipeline are possible in the form of clogging and leaks of pipelines, and therefore when installing you should predict inspectional hatch for inspection of pipelines and cleaning if there is need for it.



8 MAINTENANCE

As mentioned in Section 7, there should be inspections in mind. In terms of maintenance, we distinguish between regular maintenance and emergency maintenance.

Emergency maintenance includes replacement of certain elements of pipelines in case of damage or cleaning pipeline when it comes to clogging. The regular maintenance includes cleaning of pipelines and waste layers on the pipe walls. Cleaning and disinfection of the pipeline should be carried out by organizations or institution that is competent and accredited for this type of works.



9 DEINSTALLATION

Dismantling and removal

Dismantling and removal of the pipeline is done in the following manner, that is by the following procedure:

- drain the water from the system
- if the pipeline is guided in the walls of the building, prepare the walls so as to release the pipeline that is planned to be removed.
- dismantle the pipeline by separating the connections
- dismantled pipeline, if necessary, should be cut into shorter pieces for easier manipulation
- dismantled and cut pipes should be loaded on transport vehicle and taken to a landfill intended for plastic mass, so that the material can be recycled.

10 POST USAGE

POST USAGE PROCEDURE

As mentioned earlier, polypropylene plastic material, which are used for production of HT (PP) pipe, can be recyclable. The recycling of polypropylene does not lose its physicochemical properties, so that the recycled material can be used for the purpose of coating the motor housing, producing laundry basket and any plastic items. Peštan uses original material manufactured by renowned manufacturers for creation of the HTPP production program of pipes and fittings. While recycling, plastic materials are sorted by code, so the code for polypropylene is as follows:



11 ABBREVIATIONS

List of Abbreviations

Metric system of measuring units (SI) is used, for example. Units of force Newton (N) instead of pounds (p) and power unit Watt (W) instead kcal / h.

Conversion:

$$1 \text{ kp} = 9.80665 \text{ N ili } 1 \text{ kp} \approx 10 \text{ N}$$

$$1 \text{ Mp} = 9806.65 \text{ N ili } 1 \text{ Mp} \approx 10 \text{ kN i } 1 \text{ Mp/m} = 10 \text{ kN/m}$$

$$1 \text{ kp/cm}^2 = 9.80665 \text{ N/cm}^2 = 0.0980665 \text{ N/mm}^2 = 0.0980665 \text{ Mpa ili } 1 \text{ kp/cm}^2 \approx 0.1 \text{ N/mm}^2$$

$$1 \text{ m vodenog stubs} = 0.0980665 \text{ bar ili } 1 \text{ m vodenog stuba} \approx 0.1 \text{ bar}$$

$$1 \text{ kcal/m h step-in} = 1.16 \text{ W/mK (thermal conductivity) ili } 1 \text{ kcal/mh degrees} \approx 1.2 \text{ W/mK}$$

Thermal conductivity is given in W /mK. Division unit is the same for K and C because the difference is just at the beginning of the scale. In this sense, 1 W / m ° C is identical to 1 W /mK. K (Kelvin) is the SI unit of temperature. The temperature in Celsius (t) differs from the temperature in Kelvin (T) to 273.15 K.

$$t (\text{°C}) = T - T_0 = T - 273.15 \text{ K.}$$

in this document, f g is equal to 10 m/s, the error of approximately 2% was ignored. DN indicates the nominal diameter and PN indicates nominal pressure.

Dimensions and Units

Dimensions are expressed in mm and / or inches and are specified as a nominal value and the standard size.

d, d1, d2, d3, d4	Diameter
DN	Nominal diameter
SC	Size of hexagon screws
AL	Number of holes for the screws
s	Beam hexagonal head bolts
g	Weight in grams
SP	Quantity in standard packaging
GP	Quantity in large quantities
e	Wall thickness
PN	nominal pressure
Rp	Parallel internal pipe thread according to ISO 7-1
R	The conical outer pipe thread according to ISO 7-1
ppm	Pieces per million
1 bar	= 0.1 N/mm ² = 0.1 Mpa (Megapascal) = 14.504 psi
C	Project factor
S	series of pipes

SDR	Standard dimensional ratio
MFR	Dissolved flow coefficient according to ISO 4440
SDR	Standard dimensional ratio ratio:
OD / SDR	WT
OD / WT	SDR
OD	Outside diameter
WT	Wall thickness

Explanation of Abbreviations

PB	polybutylene
PE	polyethylene
PE-X	The cross-linked polyethylene
PP	polypropylene
PVC	polyvinylchloride
PVC-C	Chlorinated polyvinyl chloride (increased chlorine content)
PVC-U	Non-plasticised polyvinyl chloride
PVC-O	Oriental polyvinyl chloride



12 CHEMICAL RESISTANCE

TABLE OF POLYPROPYLENE CHEMICAL RESISTANCE

11.1 Introduction

This document's table sums up polypropylene chemical resistancy data, used in various countries, formed as a result of practical experience and tests.

Source: ISO/TR 10358

Table consists of chemical resistancy evaluation for the vast number of fluids estimated as aggressive or intern towards polypropylene. Evaluation is based upon values gained from results of sinking the polypropylene into fluid sample test, under the temperature 20, 60 and 100C and atmospheric pressure, and upon following the specifics of the tensile strenght under the circumstances.

Classification will be estimated with taking account of limited number of fluids considered technically or commercially important, using all the equipment that allows you testing under the pressure and coefficient determination of chemical ressistancy for every fluid separately. In this manner, these tests will provide complete information about use of polypropylene pipes for transport of the mentioned fluids including their use under the pressure.

11.2 Application area

This document contains classification of Polypropylene chemical ressistancy for about 180 fluids. It is ment to provide general instructions about possibilities of using polypropylene pipes for fluid conduction.

*Under temperatures of 20, 60 and 100C

*Under deficiency of inner pressure and outer mechanical tension (example: bending tension, pressure tension, distortion tension etc.)

11.3 Definitions and symbols as abbreviations

Criteria classifications, definitions, symbols of abbreviations used in this section are as follows:

S – satisfactory L –partial or limited

The chemical resistance of polypropylene to exposed activities fluids are classified as partially satisfactory when the test results were confirmed in most of the countries that participated in the test.

Also, this classification (L) is used for the resistance to chemical activity of the fluid in which the dependence of the parameters can be used i S i NS.

NS – not satisfactory

The chemical resistance of polypropylene exposed to fluid activity is classified as not satisfactory when the test results are confirmed in most of the countries that participated in the test.

In this classification (NS) are materials that, depending on the parameters are marked with NS or L.

Saturated - saturated aqueous solution, prepared at 20 ° C

Aqueous solution -unsaturated at concentrations higher than 10%

Diluted solution - diluted aqueous solution at concentrations equal to or lower than 10%

A working solution - water solution with normal concentration for industrial use

Solution concentrations recorded in the text are expressed in percentages by weight. Aqueous solutions of poorly soluble chemicals to which the chemical activities of the polypropylene business, considered saturated solutions. Overall, in this catalog were used common chemical names. This table napravavljena as a guide for users of polypropylene. In the case that a chemical compound is not in the table, due to uncertainties related to the chemical resistance in an application, please contact Pestan for advice and testing proposal.

Chemical or Product	Concentration	Temperature °C		
		20	60	100
Acetic acid	up to 40 %	S	S	-
Acetic acid	50%	S	S	L
Acetic acid, glacial	>96%	S	L	NS
Acetic anhydride	100%	S	-	-
Acetone	100%	S	S	-
Acephenone	100%	S	L	-
Acrylonitrile	100%	S	-	-
Air	-	S	S	S
Allyl alcohol	100%	S	S	-
Almond oil	-	S	-	-
Alum	Sol	S	S	-
Ammonia, aqueous	Sat. sol	S	S	-
Ammonia, dry gas	100%	S	-	-
Ammonia, liquid	100%	S	-	-
Ammonium acetate	Sat. sol	S	S	-
Ammonium chloride	Sat. sol	S	S	-
Ammonium fluoride	up to 20%	S	S	-
Ammonium hydrogen carbonate	Sat. sol	S	S	-
Ammonium metaphosphate	Sat. sol	S	S	S
Ammonium nitrate	Sat. sol	S	S	S
Ammonium persulphate	Sat. sol	S	S	-
Ammonium phosphate	Sat. sol	S	-	-
Ammonium sulphate	Sat. sol	S	S	S
Ammonium sulphide	Sat. sol	S	S	-
Amyl acetate	100%	L	-	-
Amyl alcohol	100%	S	S	S
Aniline	100%	S	S	-
Apple juice	-	S	-	-
Aqua regia	HCl/HNO ₃ /1	NS	NS	NS
Barium bromide	Sat. sol	S	S	S
Barium carbonate	Sat. sol	S	S	S



Chemical or Product	Concentration	Temperature °C		
		20	60	100
Barium chloride	Sat. sol	S	S	S
Barium hydroxide	Sat. sol	S	S	S
Barium sulphide	Sat. sol	S	S	S
Beer	-	S	S	-
Benzene	100%	L	NS	NS
Benzoic acid	Sat. sol	S	S	-
Benzyl alcohol	100%	S	L	-
Borax	sol	S	S	-
Boric acid	Sat. sol	S	-	-
Boron trifluoride	Sat. sol	S	-	-
Bormine, gas	-	NS	NS	NS
Bromine, liquid	100%	NS	NS	NS
Butane, gas	100%	S	-	-
Butanol	100%	S	L	L
Butyl acetate	100%	L	NS	NS
Butyl glycol	100%	S	-	-
Butil fenol	Sat. sol	S	-	-
Butyl phenols	100%	S	L	L
Calcium carbonate	Sat. sol	S	S	S
Calcium chlorate	Sat. sol	S	S	-
Calcium chlorate	Sat. sol	S	S	S
Calcium hydroxide	Sat. sol	S	S	S
Calcium hypochlorite	sol	S	-	-
Calcium nitrate	Sat. sol	S	S	-
Camphor oil	-	NS	NS	NS
Carbon dioxide, dry gas	-	S	S	-
Carbon dioxide, wet gas	-	S	S	-
Carbon disulphide	100%	S	NS	NS
Carbon monoxide, gas	-	S	S	-
Carbon tetrachloride	100%	NS	NS	NS
Castor oil	100%	S	S	-
Caustic soda	Up to 50%	S	L	L
Chlorine, aqueous	Sat. sol	S	L	-
Chlorine, dry gas	100%	NS	NS	NS

Chemical or Product	Concentration	Temperature °C		
		20	60	100
Chlorine, liquid	100%	NS	NS	NS
Chloroacetic acid	100%	S	-	-
Chloroethanol	100%	S	-	-
Chloroform	100%	L	NS	NS
Chlorosulphonic acid	100%	NS	NS	NS
Chrome alum	Sol	S	S	-
Chromic acid	Up to 40%	S	L	NS
Citric acid	Sat. sol	S	S	S
Coconut oil	-	S	-	-
Copper (II) chloride	Sat. sol	S	S	-
Copper (II) nitrate	Sat. sol	S	S	S
Copper (II)	Sat. sol	S	S	-
Corn oil	-	S	L	-
Cottonseed oil	-	S	S	L
Cresol	Greater than 90%	S	-	-
Cyclohexane	100%	S	-	-
Cyclohexanol	100%	S	L	-
Cyclohexanone	100%	L	NS	NS
Decalin (decahydronaphthalene)	100%	NS	NS	NS
Dextrin	Sol	S	S	-
Dextrin Dextrose	Sol	S	S	S
Dibutyl phthalate	100%	S	L	NS
Dichloroacetic acid	100%	L	-	-
Dichloroethylene (A and B)	100%	L	-	-
Diethanolamine	100%	S	-	-
Diethyl ether	100%	S	L	-
Diethylene glycol	100%	S	S	-
Diglycolic acid	100%	S	-	-
Diisooctyl	100%	S	L	-
Dimethyl amine, gas	-	S	-	-
Dimethyl formamide	100%	S	S	-
Dioctyl phthalate	100%	L	L	-
Dioxane	100%	L	L	-
Distilled water	100%	S	S	S



Chemical or Product	Concentration	Temperature °C		
		20	60	100
Ethyl alcohol	Up to 95%	S	S	S
Ethyl chloride, gas	-	NS	NS	NS
Ethylene chloride (mono and di)	-	L	L	-
Ethyl ether	100%	S	L	-
Ethylene glycol	100%	S	S	S
Ethanolamine	100%	S	-	-
Ethyl acetate	100%	L	NS	NS
Ferric chloride	Sat. sol	S	S	S
Ferric chloride Formaldehyde	40%	S	-	-
Formic acid	10%	S	S	L
Formic acid	85%	S	NS	NS
Formic acid, anhydrous	100%	S	L	L
Fructose	Sol	S	S	S
Fruit juice	-	S	S	S
Gasoline. petrol (aliphatic hydrocarbons)	-	NS	NS	NS
Gelatine	-	S	S	-
Glucose	20%	S	S	S
Glycerine	100%	S	S	S
Glycolic acid	30%	S	-	-
Heptane	100%	L	NS	NS
Hexane	100%	S	L	-
Hydrobromic acid	More than 48%	S	L	NS
Hydrochloric acid	More than 20%	S	S	S
Hydrochloric acid	30%	S	L	L
Hydrochloric acid	From 35 to 36%	S	-	-
Hydrofluoric acid	Dil.sol	S	-	-
Hydrofluoric acid	40%	S	-	-
Hydrogen	100%	S	-	-
Hydrogen chloride, dry gas	100%	S	S	-
Hydrogen peroxide	Up to 10%	S	-	-
Hydrogen peroxide	Up to 30%	S	L	-
Hydrogen sulphide, dry gas	100%	S	S	-
Iodine, in alcohol	-	S	-	-

Chemical or Product	Concentration	Temperature °C		
		20	60	100
Isoctane	100%	L	NS	-
Isopropyl alcohol	100%	S	S	S
Isopropyl ether	100%	L	-	-
Lactic acid	Up to %	S	S	-
Lanoline	-	S	L	-
Linseed oil	-	S	S	S
Magnesium carbonate	Sat. Sol	S	S	S
Magnesium chloride	Sat. Sol	S	S	-
Magnesium hydroxide	Sat. Sol	S	S	-
Magnesium sulphate	Sat. Sol	S	S	-
Maleic acid	Sat. Sol	S	S	-
Mercury (II) chloride	Sat. Sol	S	S	-
Mercury (II) cyanide	Sat. Sol	S	S	-
Mercury (I) nitrate	Sol	S	S	-
Mercury	100%	S	S	-
Methyl acetate	100%	S	S	-
Methyl alcohol	5%	S	L	-
Methyl amine	Up to 32%	S	-	-
Methyl bromide	100%	NS	NS	NS
Methyl ethyl ketone	100%	S	-	-
Methylene chloride	100%	L	NS	NS
Milk	-	S	S	S
Monochloroacetic acid	<85%	S	S	-
Naphtha	-	S	NS	NS
Nickel chloride	Sat. Sol	S	S	-
Nickel nitrate	Sat. Sol	S	S	-
Nickel sulphate	Sat. Sol	S	S	-
Nitric acid	Up to 30%	S	NS	NS
Nitric acid	From 40 to 50%	L	NS	NS
Nitric acid, fuming (with nitrogen dioxide)	-	NS	NS	NS
Nitrobenzene	100%	S	L	-
Oleic acid	100%	S	L	-



Chemical or Product	Concentration	Temperature °C		
		20	60	100
Oleum (sulphuric acid with 60 % of SO ₃)	-	S	L	-
Olive oil	-	S	S	L
Oxalic acid	Sat. Sol	S	L	NS
Oxygen, gas	-	S	-	-
Parafin oil (FL65)	-	S	L	NS
Peanut oil	-	S	S	-
Peppermint oil	-	S	-	-
Perchloric acid	(2N) 20%	S	-	-
Petroleum ether (ligroine)	-	L	L	-
Phenol	5%	S	S	-
Phenol	90%	S	-	-
Phosphine, gas	-	S	S	-
Phosphoric acid	Up to 85%	S	S	S
Phosphorus oxychloride	100%	L	-	-
Picric acid	Sat. Sol	S	-	-
Potassium bicarbonate	Sat. Sol	S	S	S
Potassium borate	Sat. Sol	S	S	-
Potassium bromate	Up to 10%	S	S	-
Potassium bromide	Sat. Sol	S	S	-
Potassium carbonate	Sat. Sol	S	S	-
Potassium chlorate	Sat. Sol	S	S	-
Potassium chlorite	Sat. Sol	S	S	-
Potassium chromate	Sol	S	S	-
Potassium cyanide	Sat. Sol	S	-	-
Potassium dichromate	Sat. Sol	S	S	S
Potassium ferricyanide	Sat. Sol	S	S	-
Potassium fluoride	Up to 50%	S	S	-
Potassium hydroxide	Sat. Sol	S	S	S
Potassium iodide	Sat. Sol	S	-	-
Potassium nitrate	10%	S	S	-
Potassium perchlorate	(2N) 30%	S	S	-
Potassium permanganate	Sat. Sol	S	-	-
Potassium persulphate	Sat. Sol	S	S	-

Chemical or Product	Concentration	Temperature °C		
		20	60	100
Potassium sulphate	100%	S	S	-
Propane, gas	<50%	S	-	-
Propionic acid	-	S	-	-
Pyridine	100%	L	-	-
Seawater	-	S	S	S
Silicon oil	-	S	S	S
Silver nitrate	Sat. Sol	S	S	L
Sodium acetate	Sat. Sol	S	S	S
Sodium benzoate	35%	S	L	-
Sodium bicarbonate	Sat. Sol	S	S	S
Sodium carbonate	Do 50%	S	S	L
Sodium chlorate	Sat. Sol	S	S	-
Sodium chloride	Sat. Sol	S	S	-
Sodium chlorite	2%	S	L	NS
Sodium chlorite	20%	S	L	NS
Sodium dichromate	Sat. Sol	S	S	S
Sodium hydrogen carbonate	Sat. Sol	S	S	S
Sodium hydrogen sulphate	Sat. Sol	S	S	-
Sodium hydrogen sulphite	Sat. Sol	S	-	-
Sodium hydroxide	1%	S	S	S
Sodium hydroxide	From 10 to 60%	S	S	S
Sodium hypochlorite	5%	S	S	-
Sodium hypochlorite	From 10 to 15%	S	-	-
Sodium hypochlorite	20%	S	L	-
Sodium metaphosphate	Sol	S	-	-
Sodium nitrate	Sat. Sol	S	S	-
Sodium perborate	Sat. Sol	S	S	-
Sodium phosphate (neutral)	-	S	S	S
Sodium silicate	Sol	S	S	-
Sodium sulphate	Sat. Sol	S	S	-
Sodium sulphate	Sat. Sol	S	-	-
Sodium sulphite	40%	S	S	S
Sodium thiosulphate (hypo)	Sat. Sol	S	-	-
Soybean oil	-	S	L	-



Chemical or Product	Concentration	Temperature °C		
		20	60	100
Succinic acid	Sat. Sol	S	S	-
Sulphuric acid	Up to 10%	S	S	S
Sulphuric dioxide, dry or wet	100%	S	S	-
Sulphur acid	From 10 to 30%	S	S	-
Sulphur acid	50%	S	L	L
Sulphur acid	96%	S	L	NS
Sulphur acid	98%	L	NS	NS
Sulphurous acid	Up to 30%	S	-	-
Tartaric acid	Sat. Sol	S	S	-
Tetrahydrofuran	100%	L	NS	NS
Tetralin	100%	NS	NS	NS
Thiophene	100%	S	L	-
Tin (IV) chloride	Sol	S	S	-
Tin (II) chloride	Sat. Sol	S	S	-
Toluene	100%	L	NS	NS
Trichloroacetic acid	Up to 50%	S	S	-
Trichloroethylene	100%	NS	NS	NS
Triethanolamine	Sol	S	-	-
Turpentine		NS	NS	NS
Urea	Sat. Sol	S	S	-
Vinegar	-	S	S	-
Water brackish, mineral, potable	-	S	S	S
Whiskey		S	S	-
Wines		S	S	-
Xylene	100%	NS	NS	NS
Yeast	Sol	S	S	S
Zinc chloride	Sat. Sol	S	S	-
Zinc sulphate	Sat. Sol	S	S	-

Disclaimer

The information contained in this catalog to our the information is accurate and reliable as of the day of publication. Peštan does not provide a guarantee and gives no explanation for accuracy or completeness of the information contained here, and assumes no liability in connection with the consequences of their use or for any misprint. Our products are intended for general consumption. The responsibility of the buyer is to inspect and test our products in order to ascertain the suitability of the product for customer's particular purpose. The buyer is also responsible for appropriate, safe and legal use, processing and handling our product. Here, nothing provides a guarantee. There is no liability that can be accepted and refers to the use of Peštan products in conjunction with other materials. The information contained in this catalog refers exclusively to our products when not used in conjunction with any third party.

Peštan points out that data on the chemical resistance of Polypropylene displayed in the list of chemical resistance in this catalog are based on data collected from several sources. Peštan does not guarantee the correctness and accuracy such data and accepts no liability of any loss or damage as a result of use, inability to use or the result of using catalog by the customer or any third party to whom such data can be transmitted. You are obliged to enable suitable test to ensure convenience and safety products for the intended use in accordance with applicable regulations.

13 CERTIFICATES



IGH Hrvatska



BELNIIS Belorusija



GOST R Rusija



MPA Nemačka



VUPS Češka



IMS Srbija









14 PRODUCTION PROGRAM

HT(PP) pipes & fitting up to $\varnothing 32$ do $\varnothing 160$

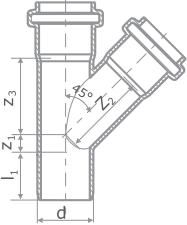

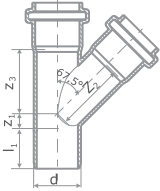

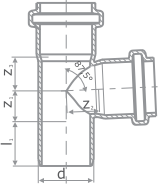
Name	Image	Code	d	Z1	Z2	L1min	
HTB Bend 15°							
		10200300	32	3	5	39	
		10200301	40	4	7	44	
		10200302	50	5	9	46	
		10200304	75	7	11	51	
		10200308	110	9	14	58	
		10200309	125	10	14	82	
HTB Bend 30°							
		10200500	32	8	13	39	
		10200501	40	14	14	44	
		10200502	50	9	12	46	
		10200508	110	17	21	58	
		10200509	125	10	15	15	
		10200510	160	29	23	23	
HTB Bend 45°							
		10200600	32	9	12	42	
		10200601	40	10	14	44	
		10200602	50	12	16	46	
		10200604	75	18	21	51	
		10200608	110	25	29	58	
		10200609	125	28	33	64	
		10200610	160	42	36	94	
HTB Bend 67.5°							
		10200700	32	13	16	42	
		10200701	40	16	19	44	
		10200702	50	19	23	46	
		10200704	75	28	32	51	
		10200708	110	40	46	58	
		10200709	125	45	50	82	
		10200710	160	64	58	94	
HTB Bend 87.5°							
		10200800	32	19	23	42	
		10200801	40	23	26	44	
		10200802	50	28	31	46	
		10200804	75	40	43	51	
			90				
		10200808	110	57	57	58	
		10200809	125	65	65	64	
10200810	160	89	83	94			

Name	Image	Code	d	Z1	Z2	Z3	L1min	
HTEA Branch 45°								
		10200900	32/32	9	40	40	42	
		10200901	40/32	5	46	44	44	
		10200902	40/40	10	49	49	44	
		10200903	50/32	-1	53	49	46	
		10200904	50/40	5	56	54	46	
		10200905	50/50	12	61	61	46	
		10200912	75/50	-1	79	74	51	
		10200914	75/75	18	91	91	51	
			90/90z					
		10200938	110/50	-17	104	91	58	
		10200940	110/75	1	116	109	58	
		10200944	110/110	25	134	134	58	
		10200953	125/110	18	144	141	64	
		10200954	125/125	28	152	152	64	
		10200963	160/110	1	168	159	81	
		10200965	160/160	36	194	194	81	
HTEA Branch 67.5°								
		10201000	32/32	13	27	27	42	
		10201002	40/40	16	33	33	44	
		10201005	50/50	19	40	40	46	
		10201038	110/50	9	72	52	58	
		10201044	110/110	40	85	85	58	
HTEA Branch 87.5°								
		10201100	32/32	19	21	21	42	
		10201101	40/32	19	25	21	44	
		10201102	40/40	23	25	25	44	
		10201103	50/32	19	30	21	46	
		10201104	50/40	23	30	25	46	
		10201105	50/50	28	30	30	46	
		10201112	75/50	27	43	31	51	
		10201114	75/75	40	43	43	51	
		10201138	110/50	28	60	32	58	
		10201140	110/75	40	60	45	58	
		10201144	110/110	57	62	62	58	
		10201153	125/110	58	69	63	64	
		10201154	125/125	65	70	70	64	
		10201164	160/125	66	87	71	81	
		10201165	160/160	83	89	89	81	



Name	Image	Code	d	Z1	Z2	Z3	L1min
------	-------	------	---	----	----	----	-------

HTEA Branch 45°

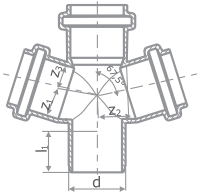

10201505	50/50/50	12	61	61	46
10201538	50/110/50	-17	104	91	58
10201544	110/110/110	25	134	134	58

HTEA DOUBLE BRANCH 67,5°

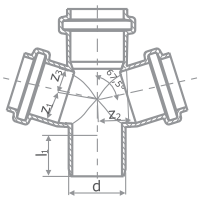

10201605	50/50/50	19	40	40	46
10201638	50/110/50	9	72	52	58
10201644	110/110/110	40	85	85	58

HTEA DOUBLE BRANCH 87,5°

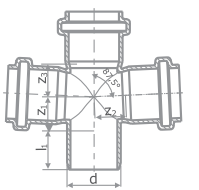





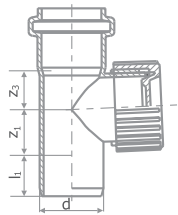



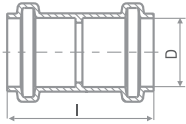

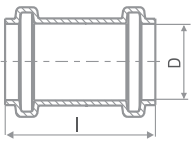
10201738	50/50/50	28	30	30	46
10201744	50/110/50	28	60	32	58

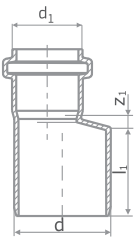
HTRE INSPECTION PIPE

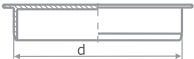

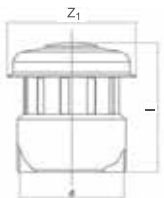
10201402	50	32		30	46
10201404	75	48		43	51
10201408	110	58		62	58
10201409	125	58		62	64

Name	Image	Code	d	Z1	l
HTU DOUBLE SOCKET					
 	10202300	32		94	
	10202301	40		103	
	10202302	50		103	
	10202304	75		109	
	10202308	110		122	
	10202309	125		138	
HTU SLEEVE SOCKET					
 	10202400	32		94	
	10202401	40		103	
	10202402	50		103	
	10202404	75		109	
	10202408	110		122	
	10202409	125		138	
HTR REDUCER					
 	10201200	40/32	10	44	
	10201201	50/32	16	46	
	10201202	50/40	12	46	
	10201208	75/50	20	51	
	10201230	110/50	40	58	
	10201232	110/75	26	58	
	10201244	125/110	15	64	
	10201253	160/110	34	81	
	10201254	160/125	27	81	
	HTM END CAP				
 	10202200	32			
	10202201	40			
	10202202	50			
	10202204	75			
	10202208	110			
	10202209	125			
	10202210	160			
	10202211	200			
HT VENTING DEVICE					
 	10202705	50	106	94	
	10202700	75	143	119	
	10202701	110	168	110	
	10202703	160	253	150	



Name	Image	Code	d	D	h	l	L1
------	-------	------	---	---	---	---	----

HTSW FLOOE WASTER GULLEY

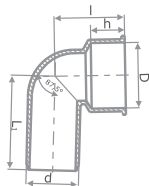

10202104	50	50,6	32,8	71	80
----------	----	------	------	----	----

HTSW FLOOE WASTER GULLEY TYPE 2							
--	--	--	--	--	--	--	--

10202101	32	46	26	51	61
10202103	40	46	26	51	75

HTSW FLOOE WASTER GULLEY TYPE 1							
--	--	--	--	--	--	--	--

10202100	32	53,7	26	51	61
10202102	40	53,7	26	51	75

Name	Image	Code (Metal grid)	Code (Plastic grid)	d	A	B	C	D	H	H1
------	-------	-------------------	---------------------	---	---	---	---	---	---	----

HT HORIZONTAL DRAIN

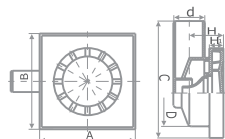

10299910	10299000	50	150	150	192	139,5	46,5	12,5
10299920	10299002	75	150	150	195	160	56,5	12,5

Name	Image	Code (Metal grid)	Code (Plastic grid)	d	A	B	C	D	H	H1
------	-------	-------------------	---------------------	---	---	---	---	---	---	----

HT VERTICAL DRAIN

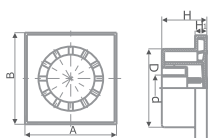

10299911	10299001	50	150	150		125	60	12,5
10299921	10299003	75	200	200		160	130	9
-	10299005	110	200	200		160	130	9
-	10299010	110	250	250		200	85	12

Name	Image	Code	d	S	L1	L2	L3	L4
------	-------	------	---	---	----	----	----	----

HTRE NON RETURNABLE VALVE

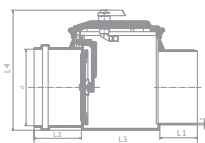

10202500	50	2,2	50	40	197	98
10202501	75	2,5	70	54	265	139
10202502	110	4,0	64	64	320	189
10202503	125	4,0	68	65	318	226
10202504	160	4,0	68	103	350	248

Name

Image

Code

d

D1

D2

s

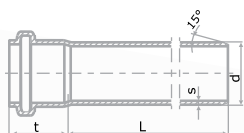
HTEM PIPE SDR41 S20

10200004

32

32,3

38,6

1,8

10200024

40

40,3

49,6

1,8

10200044

50

50,3

59,6

1,8

10200104

75

75,3

84,5

1,9

10200154

90

90,4

99,5

2,2

10200204

110

110,3

120,5

2,7

10200224

125

125,3

137,5

3,1

10200244

160

160,3

174,3

3,9

Name

Image

Code

d

D1

D2

s

HTEM PIPE SDR41 S20

19906500

32

32,3

38,6

1,8

19906511

40

40,3

49,6

1,8

19906521

50

50,3

59,6

1,8

19906531

75

75,3

84,5

1,9

19906642

90

90,4

99,5

2,2

19906541

110

110,3

120,5

2,7

19906551

125

125,3

137,5

3,1

19906561

160

160,3

174,3

3,9



