



EVO

Line Invisible



## ELIN 300

Product code:  
13700120

## ELIN 450

Product code:  
13700121

## ELIN 550

Product code:  
13700122

## ELIN 650

Product code:  
13700123

## ELIN 750

Product code:  
13700124

## ELIN 850

Product code:  
13700125

## ELIN 950

Product code:  
13700126

## ELIN 1050

Product code:  
13700127

## ELIN 1150

Product code:  
13700128

## EVO Line Invisible

EVO LINE Invisible is available in 300mm, 450mm, 550mm, 650mm, 750mm, 850mm, 950mm, 1050mm 1150mm sizes with stainless steel holder of ceramic who provides invisibility of shower drain, unlimited leveling of ceramic and has K3 load class. In this model you can chose 2 different base, depending are you gonna use it in rennovation projects or in new building. Model with Ultra Low S base have 62mm installation heigh, 25mm water seal and DN 50 mm horizontal outlet and it is used mainly for rennovation projects. Model with Standard base have 125mm installation height, 50mm water seal and DN 50 mm horizontal outlet and it is in accordance with EN 1253 and recomended to use in new building projects. Model consist "All you need set" so client have in box everything needed for the installation.



## EVO Line Invisible parts & specs

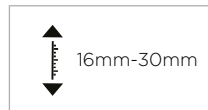
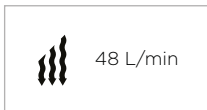
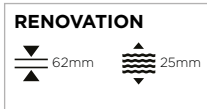

### LEGEND:

1. Height adjustment legs
2. Ultra low S Base
3. Reducer with rubber ring
4. Holder of grid
5. Grid for hair
6. Bridges for leveling of ceramic
7. Ceramic





### Anti Leaking System

Thanks to new design of holder of grid, all condensed and leaked water under the tile finds its way back to the drain. In complete with self-adhesive butyl tape which comes with product represents Anti Leak System.



### Leveling of ceramic

Model has system for grid leveling so client can have flexibility in choosing surface in bathroom. Adjusting is performed by tightening and loosening of leveling screws in grid carrier. Grid can be leveled from 16mm up to 30mm of distance between holder of grid and top of the grid.

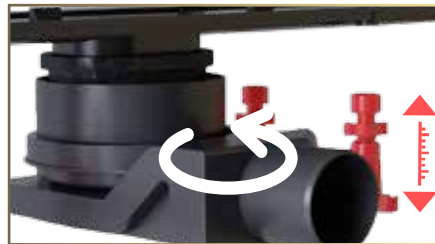

### Adjustment of drain height and base position

Universal solution for adjustment of installation height of drain and possibility of rotation of base for 360 degrees.



### 5 cm water seal set

As all of the Evolution shower drains are modular, client can with changing Ultra low S base with this 2 parts adjust all of our EVOLUTION LINE models to have 5 cm of water seal and in that way to be in accordance with EN 1253. Benefits of this model are: 15° rotatable adapter on base, Adapter on base is made from ABS so it can be connected both with push fit and solvent cement piping systems, product is in accordance with EN 1253 and this makes it perfect for new buildings projects, siphon can be cleaned very easily with simple pulling out of the cover of siphon.





## EVO Line Invisible Technical

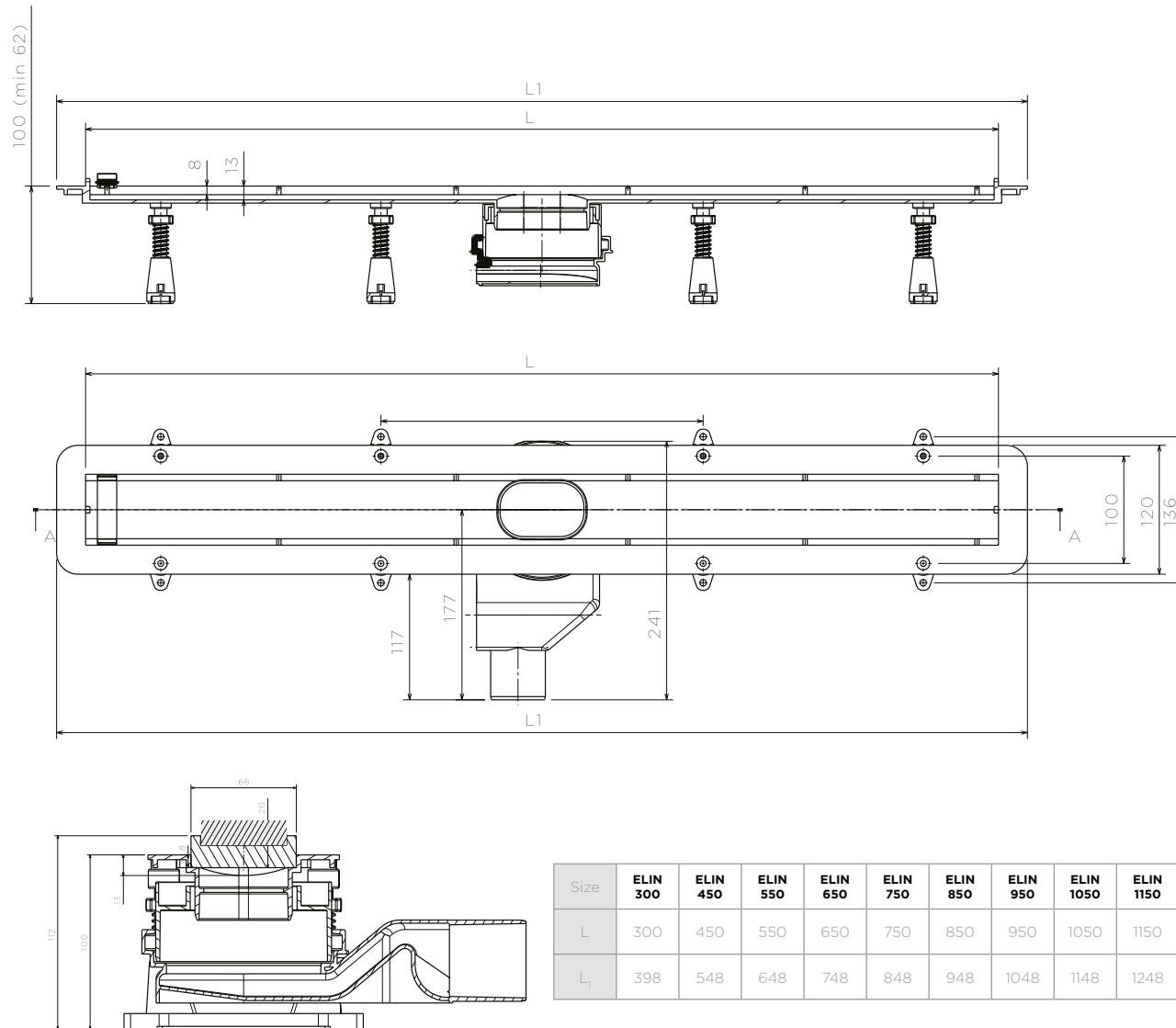

Size	ELIN 300	ELIN 450	ELIN 550	ELIN 650	ELIN 750	ELIN 850	ELIN 950	ELIN 1050	ELIN 1150
L	300	450	550	650	750	850	950	1050	1150
L <sub>1</sub>	398	548	648	748	848	948	1048	1148	1248

Thanks to new design of holder of grid, all condensed and leaked water under the tile finds it way back to the drain. In complete with self - adhesive butyl tape comes with product and makes Anti Leaking System.

Uniquesolutionforlevelingofgridofdrain in dependence of thickness of chosen ceramic by choosing different bridges for leveling. From 16mm up to 30mm.

Universal solution for adjustment of installation height of drain and possibility of rotation of base for 360 degrees. Thanks to universal solution for adjustment height of drain (DN 110mm cuttable reducer) EVO LINE shower drain have possibility of installation in both renovation and new building bathroom projects. Minimum installation height is 77mm and maximum is 110mm which fulfills all requests of modern buildings. Heigh adjustment legs enables extra security during instalation and use.

EVO LINE shower drain is manufactured in different sizes and is designed to satisfy most demanding customers regarding of their length. In dependence of your needs we offer following sizes: 650mm, 750mm, 850mm, 950mm and 1050mm.