

PRIMO SQUARE PLASTIKA



PRIMO SQUARE PLASTIKA VERTIKALNI/PRIMO SQUARE PLASTIKA HORIZONTALNI

PP plastične rešetke slivnika se proizvode u dimenzijama 150 × 150 mm i 200 × 200 mm sa 4 različite vrste otvora i rešetke izrađene od polipropilena.

NAJBITNIJE TEHNIČKE INFORMACIJE

	H Ø50	V Ø50	H Ø75	V Ø75
Minimalna visina ugradnje	59 mm	47 mm	82 mm	47 mm
Protok	48 l/min	48 l/min	84 l/min	84 l/min
Izlaz	Ø50	Ø50	Ø75	Ø75
Visina vodenog čepa	20 mm	15 mm	21 mm	15 mm
Materijal rešetke	PP			
Materijal tela slivnika	PP			

Šifra	Naziv slivnika	Težina	Dimenzija kutije/Komada u kutiji
10299050	PP SLIV.Ø50 H (REŠ.150x150) SIVA (KUT)	0,213 kg	600x400x210/20 kom
10299051	PP SLIV.Ø50 V (REŠ.150x150) SIVA (KUT)	0,213 kg	600x400x210/25 kom
10299060	PP SLIV.Ø75 H (REŠ.150x150) SIVA (KUT)	0,239 kg	400x300x270/10 kom
10299061	PP SLIV.Ø75 V (REŠ.150x150) SIVA (KUT)	0,219 kg	400x300x270/ 0 kom

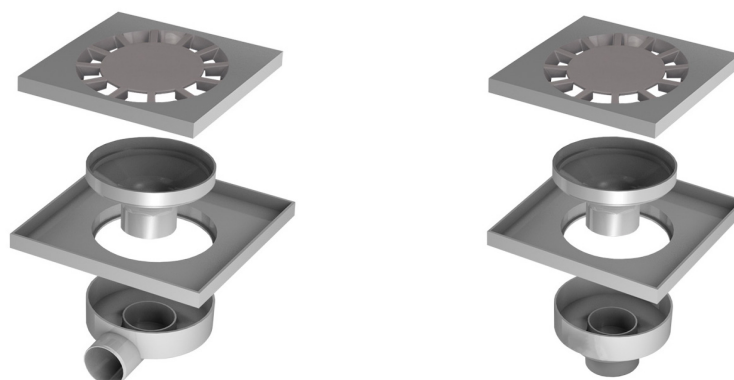

PRIMO SQUARE 150X150 V Ø50

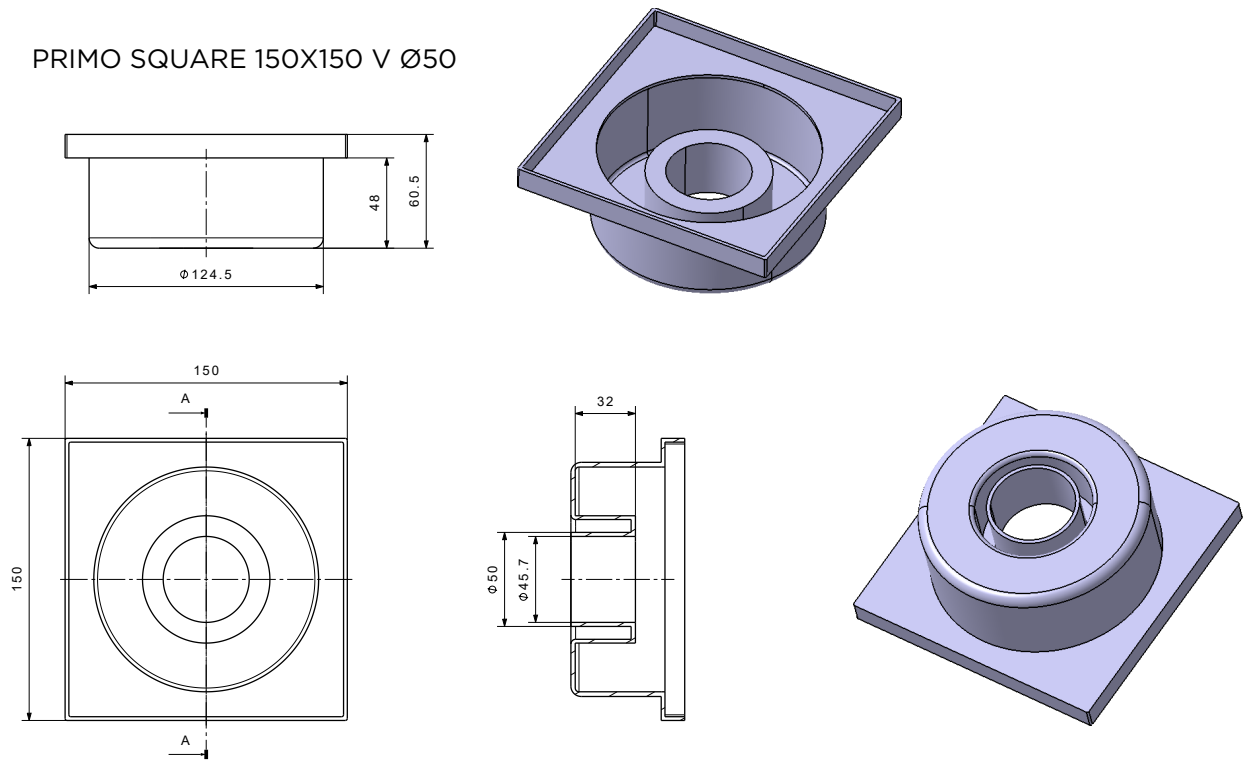

PRIMO SQUARE 150X150 V Ø75

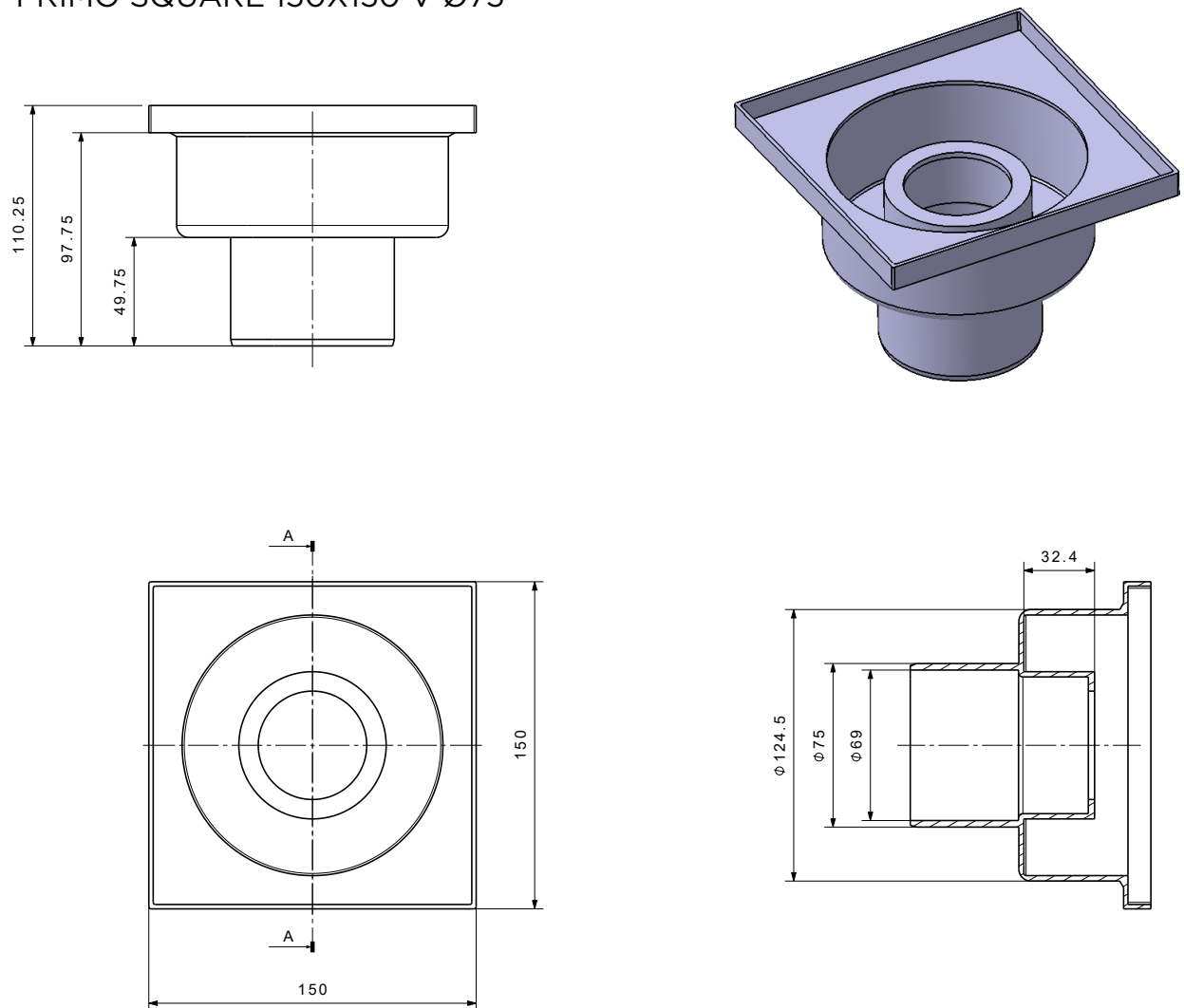

PRIMO SQUARE 150X150 H Ø50

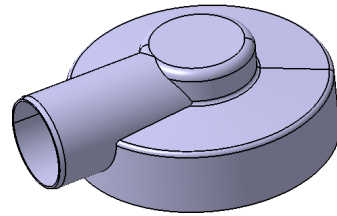
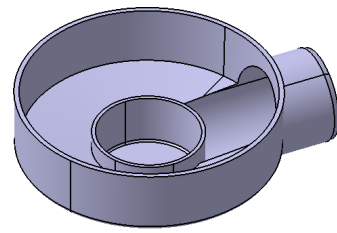
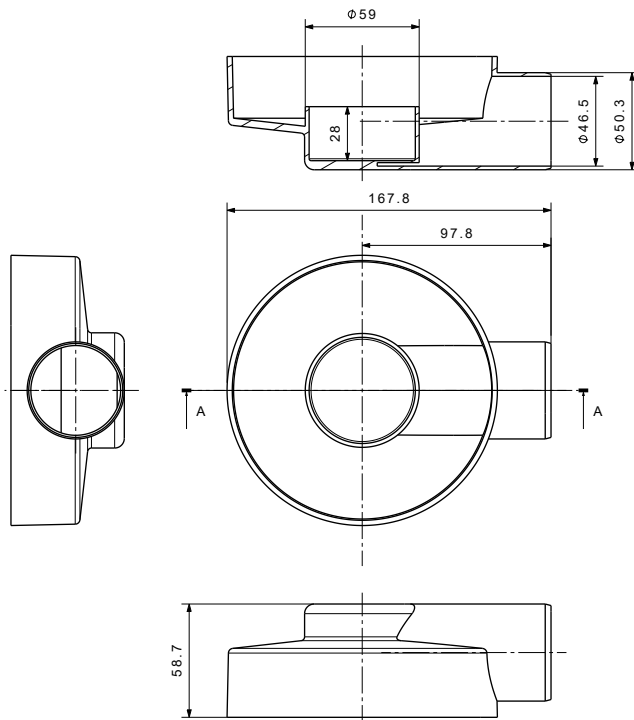

PRIMO SQUARE 150X150 H Ø75

